

# OLYMPUS®

---

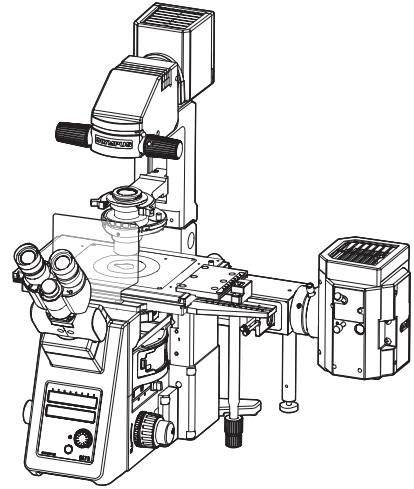

## INSTRUCTIONS

---

# IX73

## RESEARCH INVERTED MICROSCOPE

This instruction manual is for the Olympus research inverted microscope model IX73.

To ensure the safety, obtain optimum performance and to familiarize yourself fully with the use of this microscope, we recommend that you study this manual thoroughly before operating the microscope.

Retain this instruction manual in an easily accessible place near the work desk for future reference.



AX8157



In accordance with European Directive 2002/96/EC on Waste Electrical and Electronic Equipment, this symbol indicates that the product must not be disposed of as unsorted municipal waste, but should be collected separately.

Refer to your local Olympus distributor in EU for return and/or collection systems available in your country.

#### **For Korea only**

A급 기기 (업무용 방송통신기자재)

이 기기는 업무용(A급) 전자파적합기기로서 판매자 또는 사용자는 이 점을 주의하시기 바라며, 가정외의 지역에서 사용하는 것을 목적으로 합니다.

**IMPORTANT** – Be sure to read this section for safe use of the equipment. – 1-6

<b>1</b>	Intended use.....	4
<b>2</b>	Conformity of the System.....	5
<b>3</b>	Handling Precautions.....	6
<b>4</b>	Maintenance and Storage.....	6
<b>1</b>	<b>MODULE NOMENCLATURE .....</b>	<b>7</b>
<b>2</b>	<b>NOMENCLATURE .....</b>	<b>8</b>
<b>3</b>	<b>TRANSMITTED LIGHT BRIGHTFIELD OBSERVATION PROCEDURE .</b>	<b>12</b>
<b>4</b>	<b>USING THE CONTROLS .....</b>	<b>14</b>
4-1	Power Supply Unit and Microscope Frame.....	14
<b>1</b>	Turning Power On, Adjusting the Brightness.....	14
<b>2</b>	Light Path Selection.....	15
<b>3</b>	Coded intermediate magnification changer IX3-CAS.....	15
<b>4</b>	Frame Fix Plate IX3-FP.....	15
<b>5</b>	Dust tray.....	16
4-2	Focusing Block.....	17
<b>1</b>	Rotation Direction of the Coarse/Fine Adjustment Knobs.....	17
<b>2</b>	Adjusting the Coarse Adjustment Knob Tension.....	17
<b>3</b>	Detaching the Fine Adjustment Knob.....	17
<b>4</b>	Pre-focusing Lever.....	17
4-3	Stage.....	18
<b>1</b>	Placing the Specimen.....	18
<b>2</b>	Moving the Specimen.....	21
<b>3</b>	Connecting the Grounding Wire.....	22

4-4 Observation Tube.....23

- 1 Adjusting the Interpupillary Distance .....23
- 2 Adjusting the Diopter.....23
- 3 Using the Eye Shades.....24
- 4 Mounting the Eyepiece Micrometer Disk.....24
- 5 Selecting the Light Path of the Trinocular Tube.....24
- 6 Adjusting the Tilt (U-TBI90).....24

4-5 Illumination Column (IX3-ILL).....25

- 1 Tilting the Illumination Column.....25
- 2 Mounting Filters.....26
- 3 Using the Field Iris Diaphragm.....27
- 4 Adjusting the Condenser Height Adjustment Knob Tension.....27
- 5 Condenser refocusing stopper .....27

4-6 Condenser .....28

- 1 Centering the Condenser.....28
- 2 Using the Aperture Iris Diaphragm .....30

4-7 Oil- or Water-Immersion Objective .....31

- 1 Using Oil- or Water-Immersion Objective .....31

4-8 Objectives with Correction Collar.....32

**5 OTHER OBSERVATION METHODS ..... 33**

5-1 Phase Contrast Observation.....33

- 1 Phase Contrast Optical Elements and Applicable Objectives.....33
- 2 Attaching the Phase Contrast Optical Elements.....34
- 3 Centering the Phase Contrast Ring Slit.....36

5-2 Differential Interference Contrast Observation.....37

- 1 DIC Optical Elements, Applicable Objectives and DIC Sliders.....37



<b>2</b>	Attaching the DIC Optical Elements .....	38
<b>3</b>	Attaching the Analyzer and DIC Slider .....	39
<b>4</b>	Attaching the Polarizer (IX-LWPO) .....	40
<b>5</b>	Cross-Nicol Adjustment .....	41
<b>6</b>	Observation Method .....	42
5-3	Simplified Polarized Light Observation .....	43
<b>1</b>	Attaching the Analyzer and Polarizer .....	43
<b>2</b>	Observation Method .....	43
5-4	Reflected Light Fluorescence Observation (Separate Manual) .....	44
5-5	Relief Contrast Observation (Separate Manual) .....	44
<b>6</b>	<b>CAMERA RECORDING .....</b>	<b>45</b>
<b>1</b>	Camera Adapter .....	45
<b>2</b>	Changing of Light Path .....	45
<b>3</b>	Selecting the Camera Adapter Magnification .....	45
<b>4</b>	Installing the Camera Adapter .....	46
<b>7</b>	<b>TROUBLESHOOTING GUIDE .....</b>	<b>47</b>
<b>8</b>	<b>SPECIFICATIONS .....</b>	<b>49</b>
<b>9</b>	<b>ASSEMBLY .....</b>	<b>50</b>
9-1	Assembly Diagram .....	50
9-2	Detailed Assembly Procedures .....	51
<b>1</b>	Attaching the revolving nosepiece .....	51
<b>2</b>	Mounting the Illumination Column .....	52
<b>3</b>	Attaching the Halogen Bulb .....	52
<b>4</b>	Mounting the Lamp Housing .....	53
<b>5</b>	Mounting to Microscope Deck .....	54

<b>6</b>	Attaching the Stage.....	55
<b>7</b>	Attaching the Objectives.....	57
<b>8</b>	Attaching the Condenser Refocusing Stopper.....	57
<b>9</b>	Attaching the Condenser.....	58
<b>10</b>	Attaching the Observation Tube.....	59
<b>11</b>	Attaching the Eyepieces.....	60
<b>12</b>	Using the Accessory Mounting Holes.....	60
<b>13</b>	Using the Frame Fix Plate (IX3-FP).....	61
<b>14</b>	Connecting the Cables.....	62
<b>15</b>	Cable Distributions.....	63
<b>16</b>	Cable Cover.....	64
<b>10</b>	<b>LAMP HOUSING INSPECTION SHEET .....</b>	<b>65</b>

<b>■</b>	<b>PROPER SELECTION OF THE POWER SUPPLY CORD .....</b>	<b>66, 67</b>
----------	--	---------------

Caution

If the equipment is used in a manner not specified by this manual, the safety of the user may be imperiled. In addition, the equipment may also be damaged. Always use the equipment as outlined in this instruction manual.

The following symbols are used to set off text in this instruction manual.

**CAUTION** : Indicates a potentially hazardous situation which, if not avoided, may result in minor or moderate injury or damage to the equipment or other property. It may also be used to alert against unsafe practices.

◎ : Indicates commentary (for ease of operation and maintenance).

## IMPORTANT

This microscope employs UIS2 optical design.

For the applicable modules, please consult Olympus or refer to the latest brochures or Olympus website. Less than optimum performance may result if inappropriate module combinations are used.

### Configuration of Instruction Manuals

Since this microscope is expandable to a variety of systems, separate instruction manuals are prepared so that the user has to read only the manuals according to the user's own system.

Manual Name	Main contents
IX73 (this instruction manual)	Observation procedures including transmitted light brightfield, phase contrast and DIC observations
TH4	Halogen lamp power supply unit
REFLECTED FLUORESCENCE SYSTEM	Reflected light fluorescence observation
IX2-MLWCD, IX3-MLWCDA	Mid-long working distance condenser
U-AW	Motorized attenuator wheel
BX3-SSU	Scanning stage with ultrasonic
IX2-GS	Gliding stage
IX3-RSPC	Right side port with C-mount
U-CBF	Control box for fast filter wheel and shutter
IX3-CBM/U-HSCBM	Configuration and usage of the modules available in the IX73 motorized system or the IX73 motorized coded system.
U-LEDPS	LED Power supply
U-CB5S	Control Box for coded function
IX3-DICTA	Motorized DIC slider
IX3-EMDECK	Deck adaptor for U-FFWEM
IX3-EXMAD	Adapter for excitation irradiance meter

## Releasing the Transport Lock

Be sure to work on the following tasks first after finishing the unpacking.

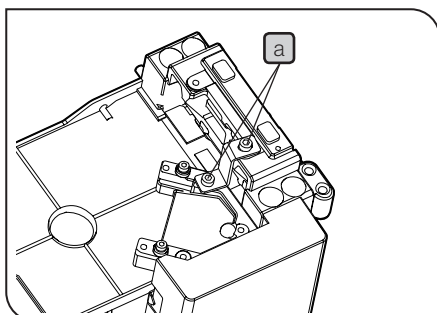

Releasing the transport lock of the focusing mechanism

**CAUTION** Never attempt to rotate the focusing knob without removing the clamping plate. Otherwise, the focusing mechanism may be damaged.

Loosen and remove the screws **a** of the clamping plate using the Allen wrench provided with the microscope.

- ⊙ Keep the clamping plate and screws in a safe place because it will be used again when the microscope is transported next time.

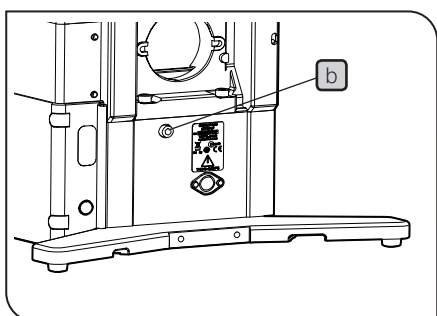

Releasing the transport lock of the light path selector

**CAUTION** Never attempt to operate the light path selector without removing the transport lock screw. Otherwise, the light path selector mechanism may be damaged.

Loosen and remove the transport lock screw **b** using the Allen screwdriver provided with the microscope.

- ⊙ Keep the lock screw in a safe place because it will be used again when the microscope is transported next time.



## SAFETY PRECAUTIONS

1. If potentially infectious samples may be observed, use protective gloves or other protective means to prevent the skin from contacting with samples directly.  
After observation, be sure to clean the portion contacted with samples.
  - Moving this device is accompanied with the risk of dropping the samples. Be sure to remove the samples before moving this device.
  - In case the samples are damaged by erroneous operation, promptly take the infection prevention measures.
  - Follow the procedures described in "Handling Precautions" (see page 6) prior to using the accessories of this device. Otherwise, the stability of the device will be lost and the dropped samples will cause the possibility of infection.
  - When you maintain the device which may have contacted with potentially infectious samples, be sure to wear protectors such as gloves, or clean the device prior to operation.
  - Before disposing of the device contacted with potentially infectious samples, be sure to follow the regulations and rules of your local government.
2. Be careful not to have your hand caught between the bottom of the revolving nosepiece and the microscope frame.
3. The microscope is not provided with a waterproof mechanism. Therefore, if culture liquid or water is spilt on the stage, revolving nosepiece or microscope frame, damage to the equipment or an electrical shock may result. Immediately wipe the liquid or water off if it is spilt on them.
4. The microscope is not provided with a dust-proof mechanism.
5. Install the microscope on a sturdy, level table or bench.
6. When moving the microscope, remove the modules that may drop including the specimen from the microscope in advance, then carefully carry the microscope frame by holding the base (front edge) **a** and the grasping part below the illumination column **b**.
7. When carrying the microscope to a different place, it is also recommended to disconnect all cables and modules from the microscope frame.  
When transporting it, also engage the transport lock mechanisms and package it sufficiently.  
Also be careful against slipping of hands during carrying.
8. Damage to the microscope will occur if you grasp it by other parts including the stage, focusing knob, etc.
9. This microscope is not equipped with laser safety mechanisms. The user should assume liabilities for any consequence of user modification including introduction of the use of a laser beam.
10. If laser equipment is attached to the product you have purchased, this Instruction Manual is not effective. Follow the Instruction Manual provided with the laser equipment to be attached.
11. The surfaces of the lamp housing will become extremely hot during operation. When installing the microscope, make sure to allow ample free space (10 cm or more) around and in particular above the lamp housing.
12. When installing the microscope, route the power cord away from the lamp housing. Should the power cord come in contact with a hot part, the power cord could melt and cause electric shock.

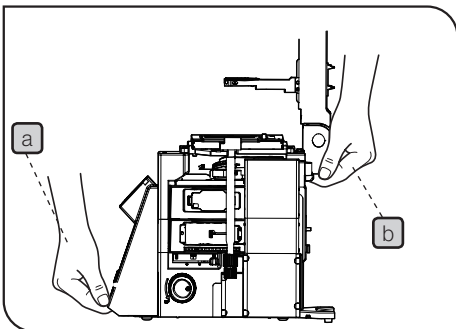

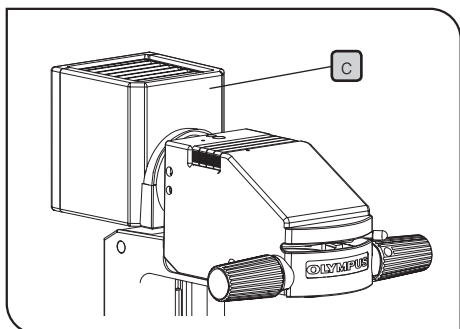





13. After operation or in case of abnormality, be sure to disconnect the power cord from the connector on the products or from the outlet.
14. To avoid potential shock hazards and burns when replacing the lamp bulb, set the main switch to "O" (OFF) then disconnect the power cord from the wall outlet in advance. Whenever you replace the bulb during use or right after use, allow the lamp housing **C** and bulb to cool before touching.

Designated bulb	12V100WHAL-L (PHILIPS 7724)
-----------------	-----------------------------

15. Do not permit tools or metal fragments to get into air vents, or other apertures. Doing so could cause failure of the microscope or electric shock to the user.
16. The standard service life of the lamp housing is eight (8) years of use or 20,000 hours of total power ON period, whichever is the shorter period. For details, see the Inspection Sheet on page 65.
17. During the fluorescent observation, be sure to attach the antiglare plate to the microscope to protect your eyes.
18. If you feel bright during observation through eyepieces, darken the illumination light by adjusting the brightness of the light source or using the ND filter. Use the equipment according to the regulations for workers health and safety, if any.
  - Europe: 2006/25/EC Directive for protecting workers from risks caused by physical factors (artificial optical radiation).
19. Do not look directly at the light from the objective lens or the specular reflection light of the specimen.
20. Be careful invisible wavelength light (ultraviolet or infrared) may be emitted depending on illumination methods.
21. If the skin is exposed to the light from the objective lens for a long time, it may cause burns. Be sure to avoid it.
22. Do not place flammable gas or liquid close to the light from the objective lens. It may cause fire.
23. This device complies with the emission and immunity requirements described in IEC61326 series.
24. The electromagnetic environment should be evaluated prior to operation of this device. Do not use this device in close proximity to the sources of strong electromagnetic radiation to prevent interference with the proper operation.
25. Always use the power cord provided by Olympus. If no power cord is provided, please select the proper power cord by referring to the section "PROPER SELECTION OF THE POWER CORD" at the end of this instruction manual. If the proper power cord is not used, the safety and EMC performance of the device can not be assured.
26. Always connect the power cord correctly and ensure that the grounding terminal of the device and that of the wall outlet are properly connected. If the device is not grounded, our intended electric safety and EMC performance of the device can not be assured.
27. It is discommended to stare at the light directly from the LED light source composed in this product for long hours as this could damage your eye. Use the equipment in accordance with the regulations for Workers Health and Safety, if any.



## Safety Symbols

The following symbols are found on the microscope. Study the meaning of the symbols and always use the equipment in the safest possible manner.

Symbol	Explanation
	Indicates that the surface becomes hot, and should not be touched with bare hands.
	Indicates a non-specific general hazard. Follow the description given after this symbol or in the instruction manual.
	Indicates that the main switch is ON.
	Indicates that the main switch is OFF.

## Caution labels

Caution labels are placed at parts where special precaution is required when handling and using the microscope. Always pay attentions to the caution labels.

Positions of caution labels	Lamp housing	 
	Back side of microscope frame	

If the caution label becomes dirty or is peeled off, contact Olympus for replacement.

## 1 Intended use

This device has been designed to be used to observe magnified images of specimens in various routine work and research applications.

Do not use this device for any purpose other than its intended use.



This product complies with the requirements of directive 98/79/EC concerning in vitro diagnostic medical devices. CE marking means the conformity to the directive.

EN61326-1 defines two categories according to the location for use.

Class A : Equipment suitable for use in establishments other than domestic, and those directly connected to a low voltage power supply network which supplies buildings used for domestic purposes.

Class B : Equipment for use in domestic establishments, and in establishments directly connected to a low voltage power supply network which supplies buildings used for domestic purposes.

This product is applied Class A. Some interference may occur if this system is used in domestic location.

USA: CAUTION:

Federal law restricts this device to sale by or on the order of an appropriately licensed healthcare practitioner.

## 2 Conformity of the System

### Restrictions in use

- 1) An intermediate attachment with a thickness of up to 60 mm can be mounted between the microscope frame and binocular observation tube (U-BI90).
- 2) When the U-AW or U-FSHU is used with the transmitted light illumination setup, periphery of the field of view will be obscured with the 4X objective. When U-LHEAD is combined with U-AW or U-FSHU, or if U-FSHU is attached to IX3-ILL directly, the insufficient peripheral light will be mitigated.
- 3) Image acquisition by the digital camera is not recommended in the combination of U-TV0.35XC and IX3-CAS (2X) because of an incidence of the spot flare.
- 4) When the motorized attenuator wheel / fast filter / shutter system (U-AW,U-FFW,U-FSHU) are attached to the reflected fluorescence illuminator (IX3-RFA, IX3-RFAL, IX3-RFALFE) for the fluorescent observation, the peripheral light becomes insufficient due to obscuring the illumination light.
- 5) If IX3-RFAL or IX3-RFALFE is mounted such that the lamp house is positioned on the left side facing to the microscope and also the operation part of U-DULHA faces upward, the lamp house to be attached to U-DULHA may interfere by hitting the camera attached to the left side port.
- 6) When the U-DPCAD is attached on the left side port, some camera may not be mounted on the back side camera port depending on its size.
- 7) When you use IX3-LHLEDC for phase contrast observation / simple polarized light observation / dark field observation / observation with high magnification, if the illumination light is not sufficient, use the halogen lamp housing.
- 8) If you use IX3-LHLEDC for observation with the 4X objective, uneven illumination becomes slightly larger comparing to the halogen lamp.
- 9) If all conditions described below are met, the flares may be noticeable combining IX-ATU + U-TR30 series or U-TBI90.
  - IX73P1F
  - High contrast specimens are being observed.
  - Transmitted bright field observation is being used.
  - The aperture iris diaphragm is being narrowed down closer to the minimum.
- 10) If you use 1.6X or 2X of IX3-CAS for the simple polarized light observation using IX3-AN, the contrast may be difficult to view in some cases.
- 11) If you use IX73P2F for phase contrast observation or relief contrast observation with IX3-AN engaged in the light path, a thin shading may occur in the periphery of the field of view. Remove IX3-AN from the light path before observation.

### Decks of IX73

The IX73P2F is equipped with two decks, 1st deck (upper deck) and 2nd deck (lower deck), accepting optional accessories such as the intermediate magnification changer, mirror unit cassette, etc. Refer to the following table at the time of installation of each accessory, since some accessories can be attached on either 1st deck or 2nd deck only.

	1st deck(upper deck)	2nd deck(lower deck)
Motorized fluorescent mirror turret : IX3-RFACA	○	○
Coded fluorescent mirror turret : IX3-RFACS	○	○
Right side port with C-mount : IX3-RSPC	○	○
Coded intermediate magnification changer : IX3-CAS	X	○
Deck adaptor for U-FFWEM : IX3-EMDECK	○	○

Detail of decks, see page 54.

### 3 Handling Precautions

1. These products are precision instruments. Handle them with care and avoid subjecting them to sudden or severe impact and also connect the cables gently.
2. Do not use the microscope where it is subjected to direct sunlight, high temperature and humidity, dust or vibrations. (For operating conditions, see Chapter 8, "SPECIFICATIONS" on page 49.)
3. When attaching or detaching any accessory, make sure to proceed in a condition that nothing is attached on the left side port.
4. To prevent malfunction, do not replace modules or connect/disconnect cables while the main switch of the IX3-CBM is set to "I" ON.
5. Do not disassemble any part of the microscope. Doing so could cause failure of the microscope.
6. Before disposing of this product, be sure to follow the regulations and rules of your local government.

### 4 Maintenance and Storage

1. Do not leave stains or fingerprints on the lenses and filters. Blow away dust with a commercially available blower and gently wipe the lens or filter with a piece of cleaning paper (or clean gauze).  
For wiping fingerprints and oil stains, use a piece of cleaning paper moistened with commercially available absolute alcohol.

#### CAUTION

**Since the absolute alcohol is highly flammable, it must be handled carefully. Be sure to keep it away from open flames or potential sources of electrical sparks --- for example, electrical equipment that is being switched on or off, which could cause ignition of a fire.**

**Also remember to always use absolute alcohol only in a well-ventilated room.**

2. Do not use organic solvents, which cause painted and plastic parts to deteriorate. Do not use organic solvents to clean device components other than the glass components. To clean them, use a lint-free, soft cloth slightly moistened with a diluted neutral detergent.
3. This microscope is not provided with a dust-proof mechanism. When not using the microscope, make sure to set the main switch to "O" (OFF), confirm that the lamp housing is cool enough and cover the microscope with the provided dust cover.



# 1 MODULE NOMENCLATURE

◎ The modules shown below are only the basic modules. As there are other modules which can be combined with the microscope but are not shown below, please also refer to the latest Olympus brochures or your dealer.  
For information on the modules marked with “\*”, refer to their instruction manuals.

Modules marked ★ are components of the IX73 motorized system. Also you can configure the IX73 motorized coded system in combination with modules marked #. For details, refer to IX3-CBM instruction manual.

Modules marked # are components of the IX73 coded system. For details, refer to U-CB5S instruction manual.

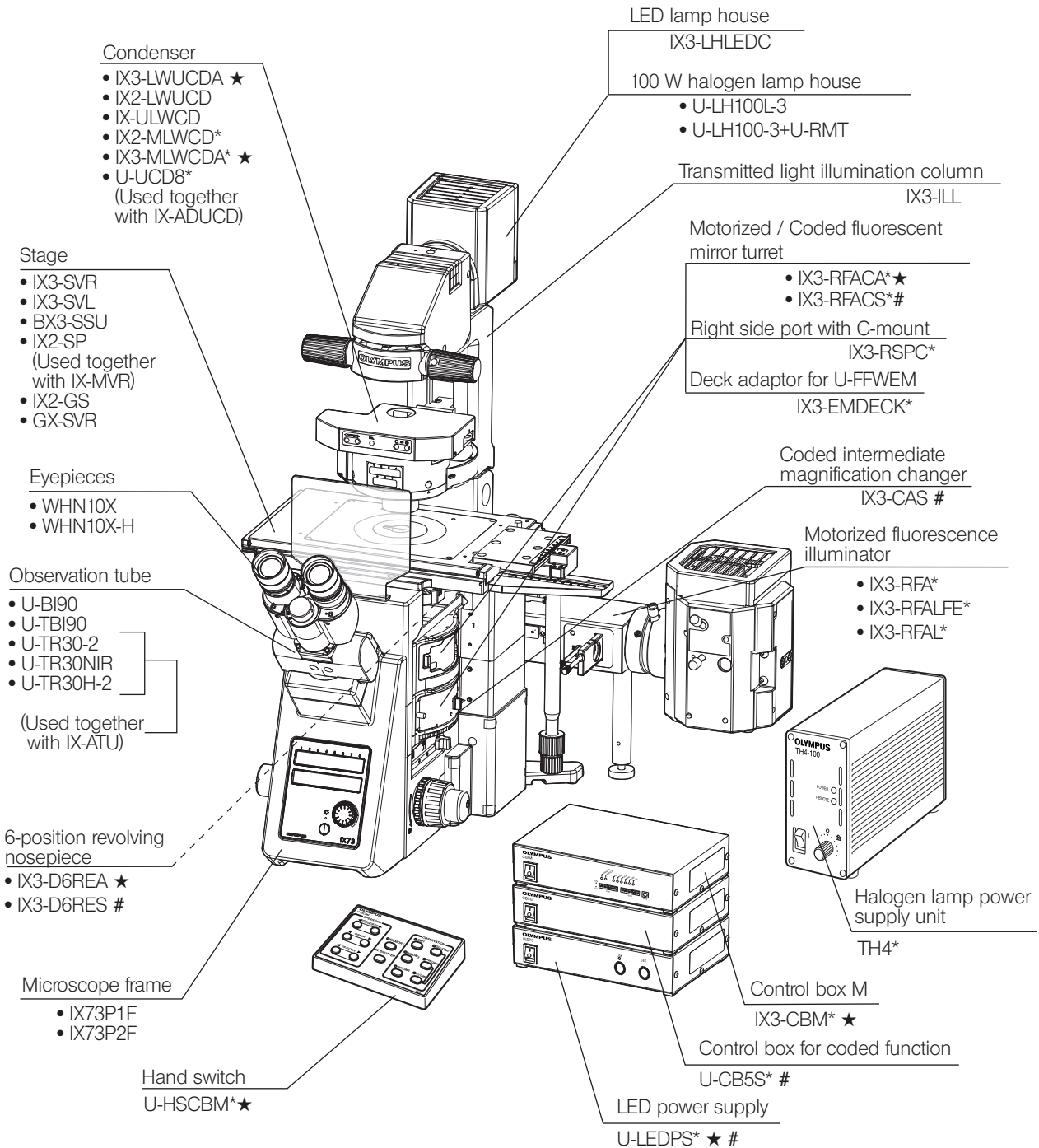

◎ Install IX3-CBM, U-CB5S and U-LEDPS on top of the other.

# 2 NOMENCLATURE

☉ If you have not yet assembled the microscope, read Chapter 9, "ASSEMBLY" (pages 50 to 64).

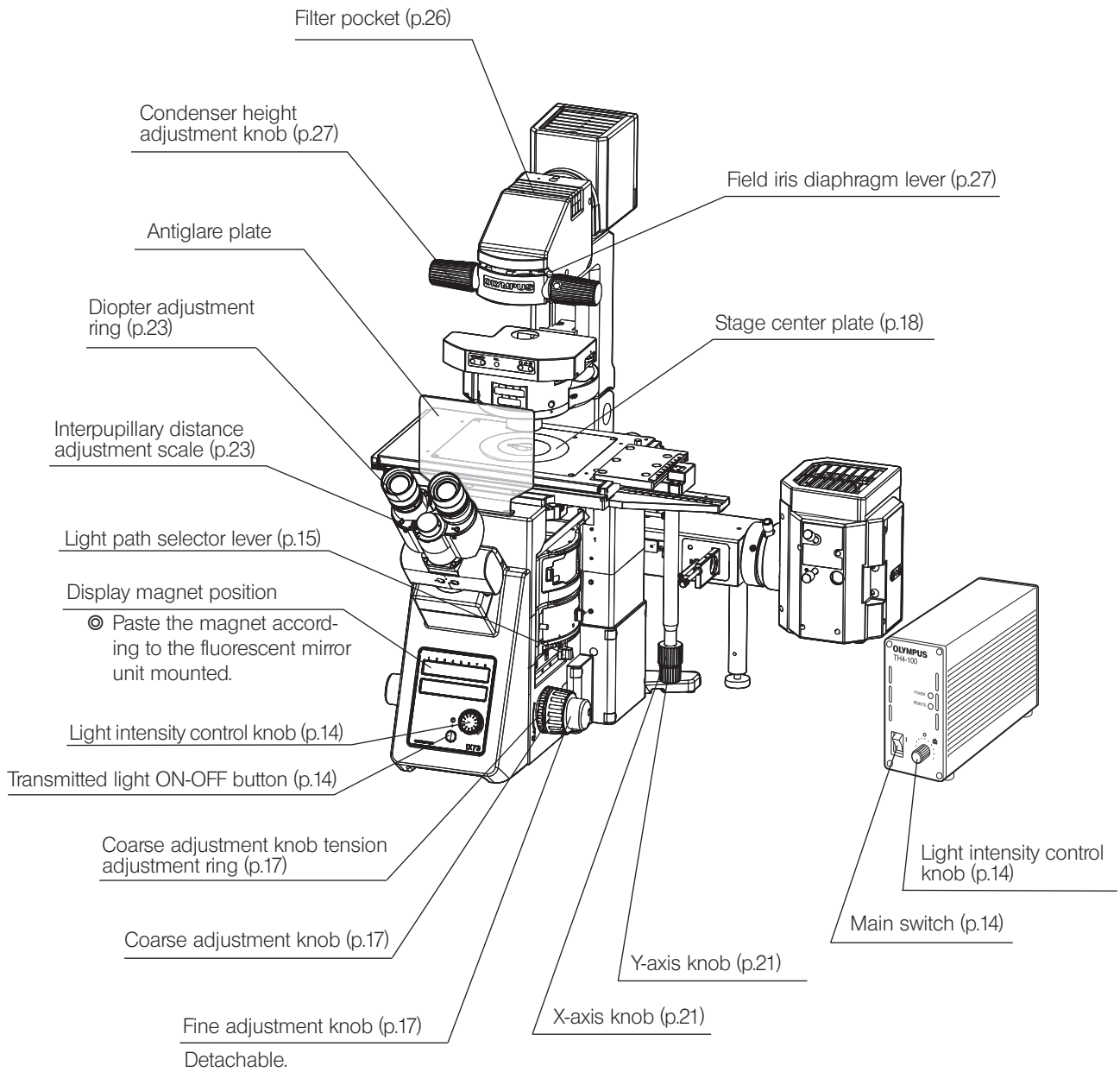

Left Side View of Microscope

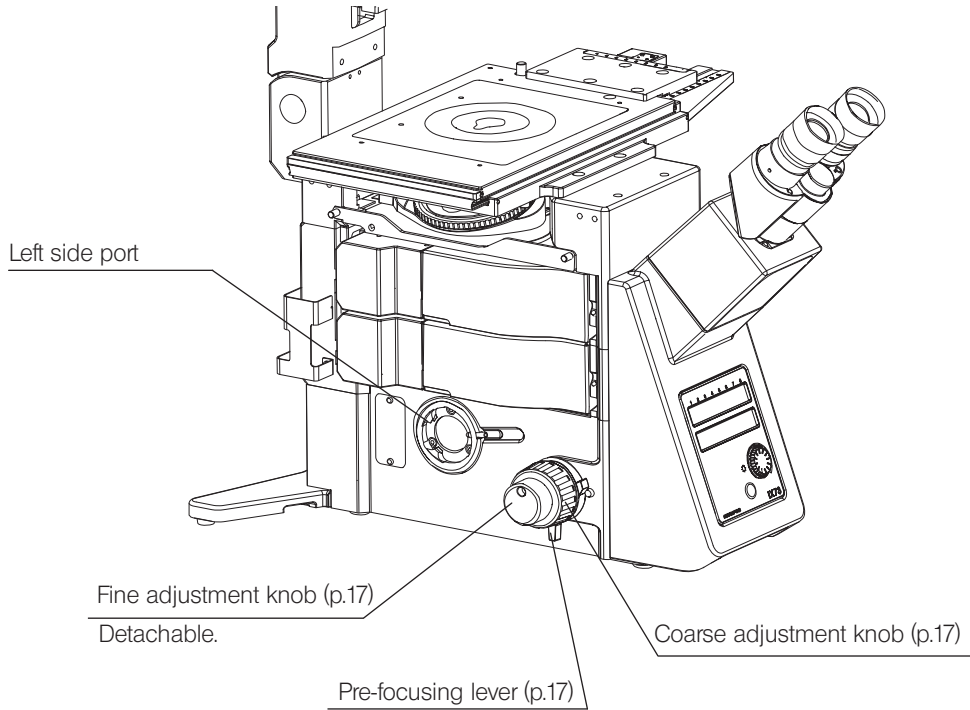

Other Modules

Motorized LWD condenser  
IX3-LWUCDA

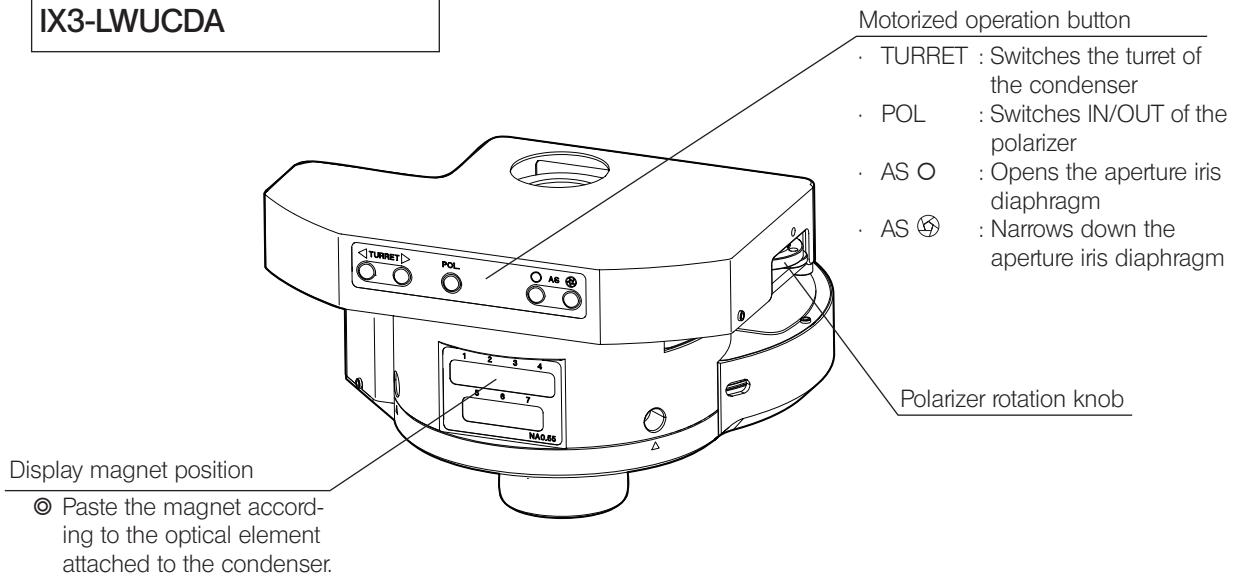

### LWD Universal Condenser IX2-LWUCD

☉ This is a manually controlled condenser.

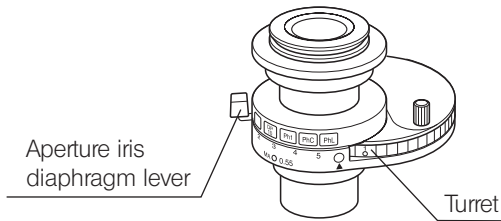

### UCD-Adapter IX-ADUCD

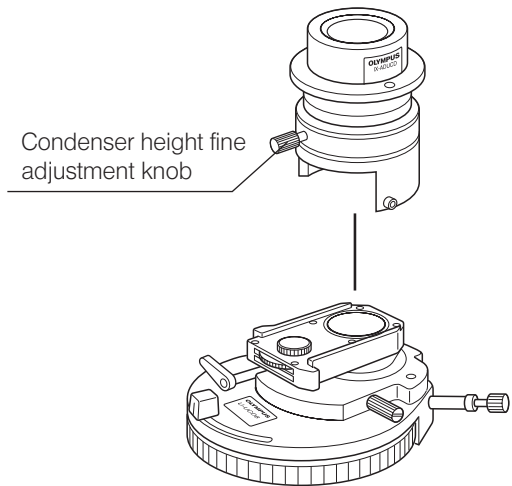

### ULWCD Condenser IX-ULWCD

☉ This is a manually controlled condenser.

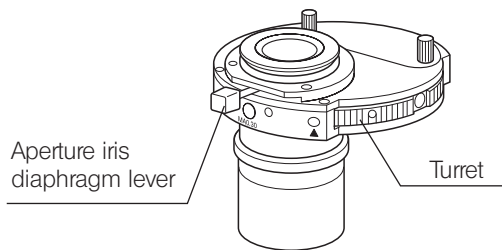

### Universal Condenser U-UCD8

☉ This is a manually controlled condenser. Refer to the separate instruction manual for details.

### Hand Switch U-HSCBM

Before use, post the number stickers/indication stickers (provided with IX3-CBM or IX3-MLWCDA). For details, read the instruction manual for the IX3-CBM/U-HSCBM or IX3-MLWCDA.

\*These buttons are defeated when the coded 6 position nosepiece IX3-D6RES or the coded fluorescent mirror turret IX3-RFACS is used.

☉ The functions of the button are different when it is use with the IX3-MLWCDA. For details, read the instruction manual for the IX3-MLWCDA.

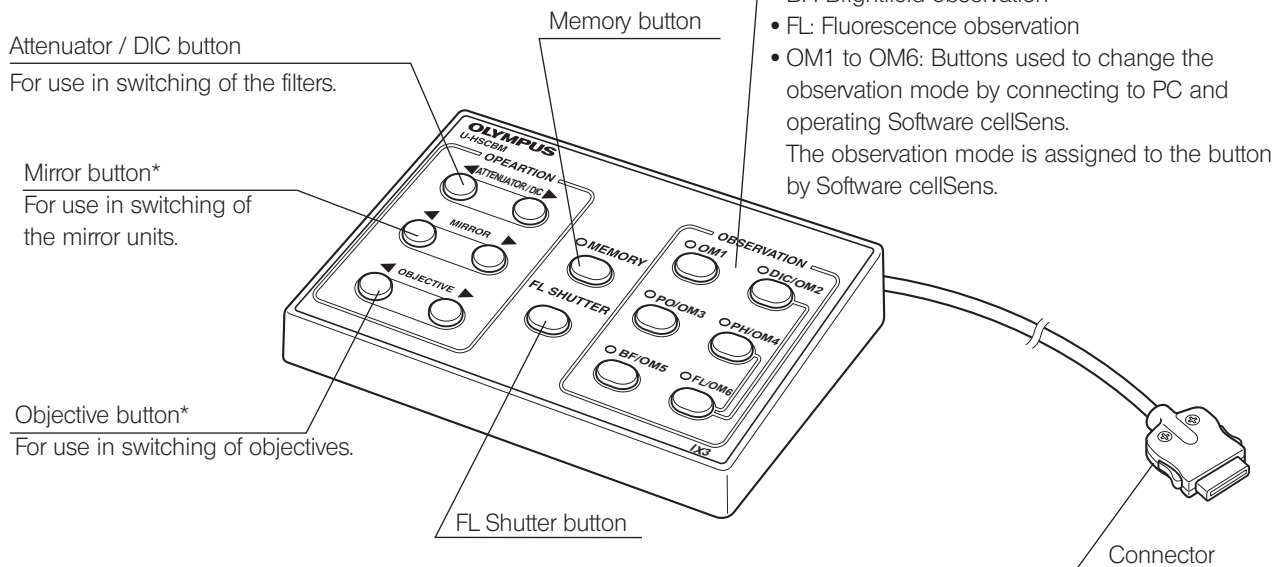

- Observation button
- DIC: Differential interference contrast observation
  - PO: Polarized light observation
  - PH: Phase contrast observation
  - BF: Brightfield observation
  - FL: Fluorescence observation
  - OM1 to OM6: Buttons used to change the observation mode by connecting to PC and operating Software cellSens. The observation mode is assigned to the button by Software cellSens.

Note: Digital images captured by cellSens are not intended for clinical diagnostic use.

**Plain Stage  
IX2-SP**

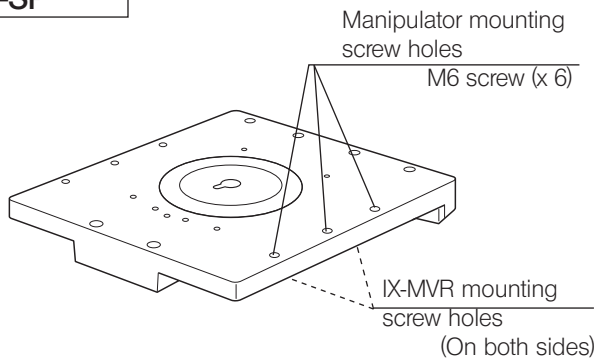

**Mechanical Stage  
IX-MVR**

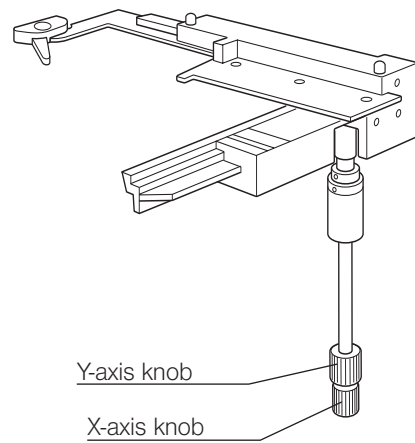

**Mechanical stage with right handle  
IX3-SVR**

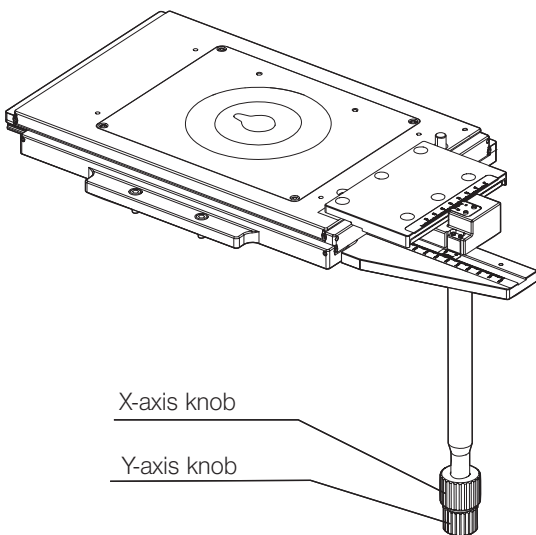

**Mechanical stage with short left handle  
IX3-SVL**

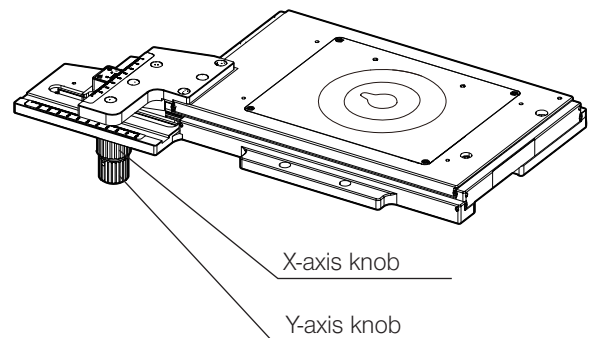

**Halogen Lamp Power Supply Unit  
TH4**

© The applicable halogen bulb is the 12V100WHAL-L.  
For details, refer to the separate instruction manual.

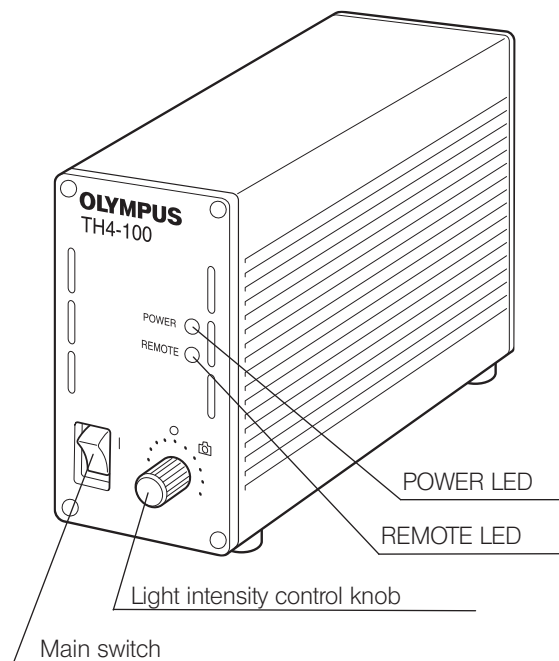

# 3 TRANSMITTED LIGHT BRIGHTFIELD OBSERVATION PROCEDURE

© The following flow shows the operating procedure for the transmitted light brightfield observation which is the basic observation method of this microscope. The operating procedures for phase contrast observation and DIC observation will be described separately in Chapter 5, "OTHER OBSERVATION METHODS" on page 33.

For the fluorescence observation, refer to the separate instruction manual entitled "Manual / Motorized Reflected Fluorescence System".

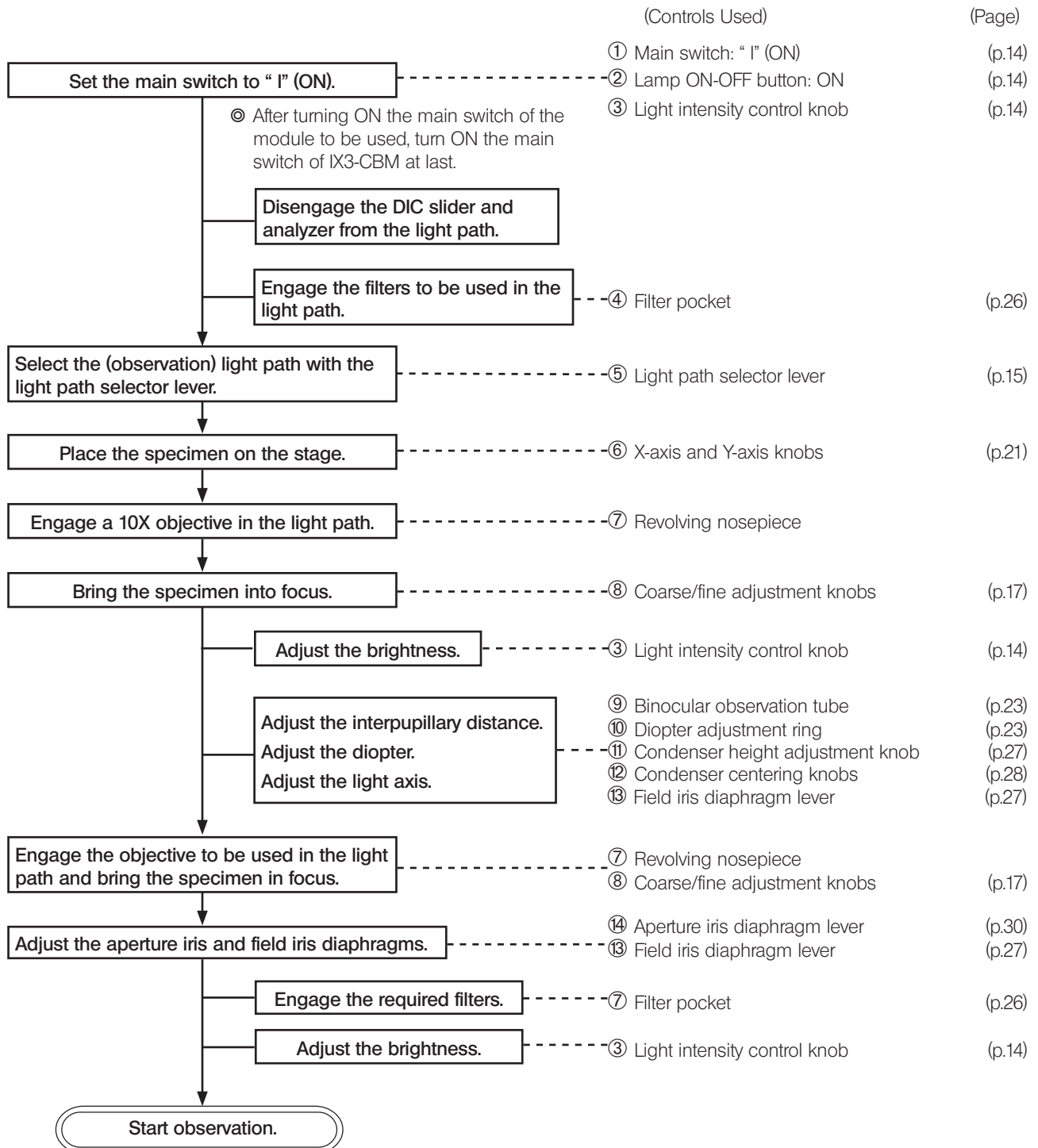

© When you turn OFF the power, turn OFF the main switch of IX3-CBM first and then turn OFF the main switch of the other modules.7

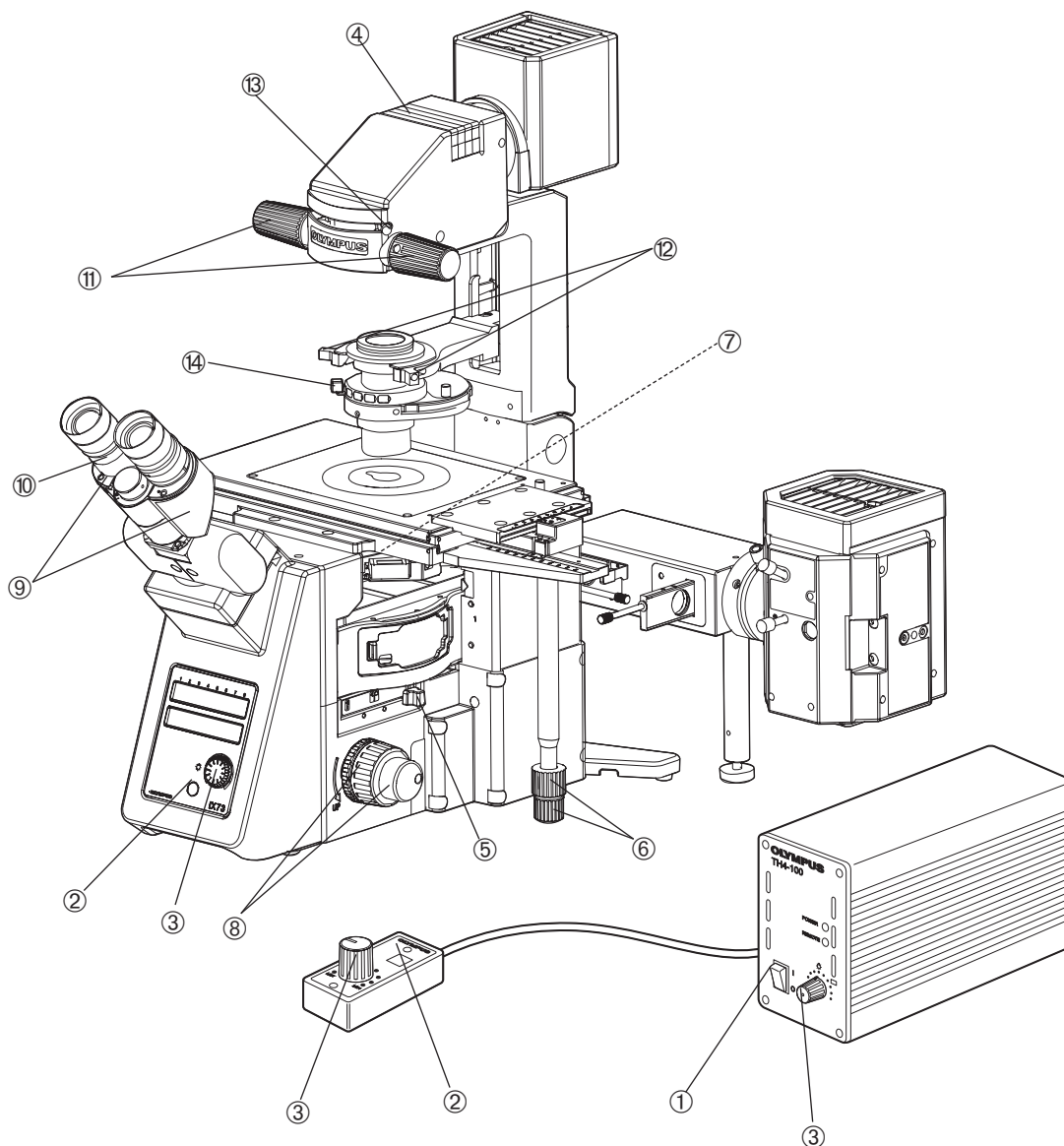

© Make a photocopy of the observation procedure pages and post it near your microscope.



# 4 USING THE CONTROLS

## 4-1 Power Supply Unit and Microscope Frame

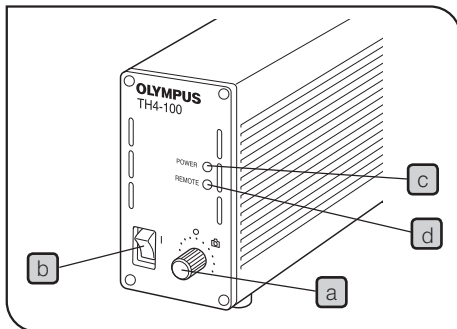

### 1 Turning Power On, Adjusting the Brightness

#### With the TH4

- 1 Make sure that the light intensity control knob **a** is in the MIN (minimum intensity) position and set the main switch **b** to "ON". (The POWER LED **c** lights up.)
- 2 Rotate the knob **a** toward MAX (maximum intensity) to increase the intensity and the illumination brightness.

Ⓞ With the TH4, the position (approx. 9 V) marked  indicates the position where the daylight illumination suitable for photomicrography is obtained when the 45LBD filter is engaged in the light path.

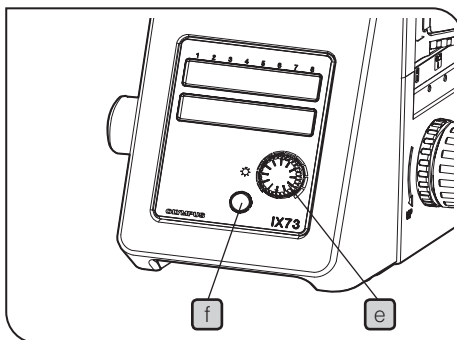

#### With the IX73 Frame

Ⓞ If the power supply connection cable provided with the microscope is connected to the TH4 (the REMOTE LED **d** lights in this case), the light intensity control knob **a** on the power supply unit is defeated and only the light intensity control knob **e** on the front of the microscope is available.

- 1 Press the transmitted light ON-OFF button **f** (so that the LED is illuminated) and adjust the brightness with the light intensity control knob **e**.
- 2 To turn the lamp OFF, set the transmitted light ON-OFF button **f** to OFF.

**CAUTION** The microscope is in standby mode when the REMOTE LED **d** is lit. Power of about 2.5 W is consumed in this period.

When the microscope system is not be used for a long period, set the main switch **b** to "OFF".

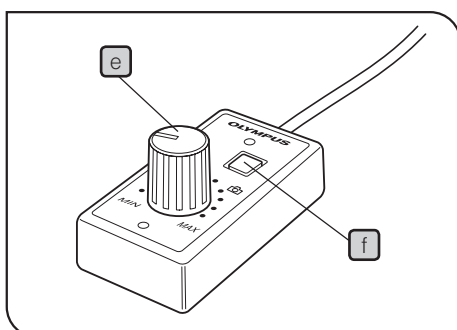

#### When the TH4-HS Hand Switch is Used

Ⓞ The illumination brightness can be adjusted from the hand switch in the same way as on the IX73 microscope.

The hand switch is provided with double-sided adhesive tape, so it can be adhered to an easy-to-use position.



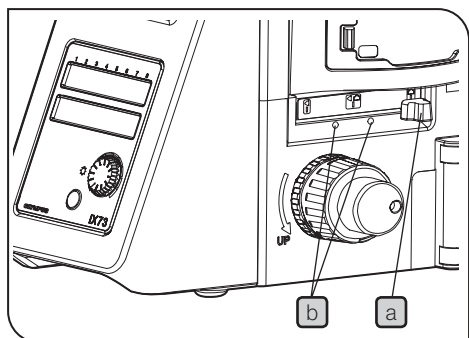

## 2 Light Path Selection

⊙ The light path selector lever **a** allows for light path switching between the observation and left side port paths.

	Eyepiece	/	Camera (Left side port)
◀	100%	/	0%
◀ [camera icon]	50%	/	50%
[camera icon]	0%	/	100%

⊙ If acquiring the image by setting the light path as [Eyepiece 50%/ Left side port 50%], the light such as fluorescent lamp may enter from the eyepiece to be reflected in the acquired image.

⊙ Attaching the M4 screw provided with the microscope to either one of screw holes **b** allows switching the light path in 2 levels.

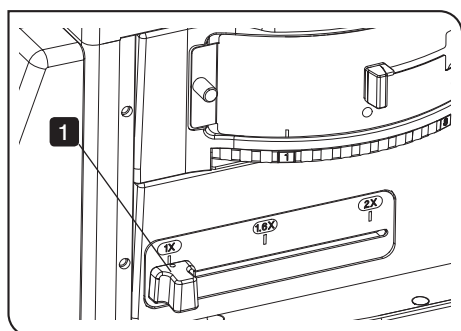

## 3 Coded intermediate magnification changer IX3-CAS

Use the coded intermediate magnification changer IX3-CAS to switch the observation magnification in the following 3 levels according to the objective lens magnification.

- 1X
- 1.6X
- 2X

For the assembly procedure, refer to page 54 .

**1** Change the magnification by operating the changing slider.

## 4 Frame Fix Plate IX3-FP

⊙ This is the module for clamping the microscope onto an antivibration platform. The applicable anti-vibration platforms are the following four models.

- 25 mm pitch and 50 mm pitch anti-vibration platforms.
- 1-inch pitch and 2-inch pitch anti-vibration platforms.

For the assembly procedure, refer to page 61

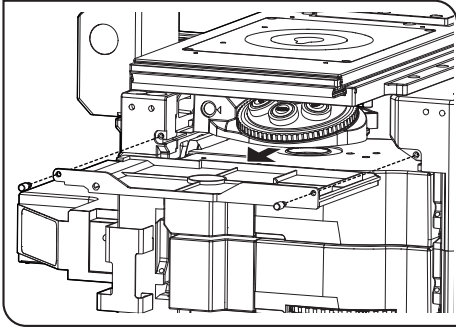

## 5 Dust tray

⊙ This tray prevents dust, etc. from falling into the microscope.  
Remove and clean it on a regular basis.

**1** Rotate the fixing screws (2 pcs.) to remove them.

**2** Slide the dust tray to remove it.

⊙ Wash the dust tray with water and wipe it with the dry cloth to dry well before attaching it to the microscope.

## 4-2 Focusing Block

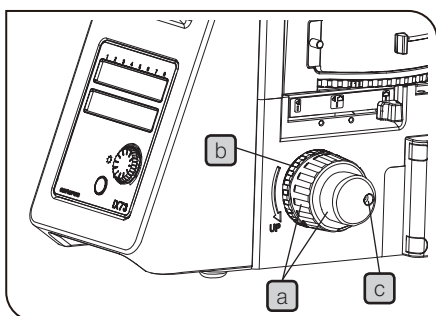

### 1 Rotation Direction of the Coarse/Fine Adjustment Knobs

- ⊙ Rotating the coarse or fine focus adjustment knob **a** toward the front (in the direction of the arrow) raises the objective and toward the rear (opposite direction) lowers the objective.

### 2 Adjusting the Coarse Adjustment Knob Tension

- ⊙ Always use the rotation tension adjustment ring **b** to control the rotation tension of the coarse adjustment knob.

The tension of the coarse adjustment knob has been pre-adjusted to optimum tension, but this can be changed as required. Turn the rotation tension adjustment ring **b** in the direction of the arrow to decrease the knob's tension and in the opposite direction to increase it.

### 3 Detaching the Fine Adjustment Knob

- ⊙ The fine adjustment knob is designed detachable in order to prevent interference between the knob and the operator's hand manipulating the X- and Y-axis knobs.
- Loosen the clamping screw **c** using the Allen screwdriver provided with the microscope and remove the fine adjustment knob.
- After detaching, the fine adjustment knob is hollowed to facilitate manipulation with a fingertip.

### 4 Pre-focusing Lever

- ⊙ The pre-focusing lever prevents collision between the specimen and objective and simplifies the focusing operation.

After bringing the specimen into approximate focus with the coarse adjustment knob, turn the pre-focusing lever **d** in the direction of the arrow to lock it. Hereafter, the upper limit of the coarse adjustment will be limited at the position where the lever is locked.

When bringing a specimen in focus, approximate focus can be obtained by simply raising the coarse adjustment to the stop position so all you have to do additionally is control the fine adjustment knob.

- ⊙ The focusing function using the fine adjustment knob is not limited.

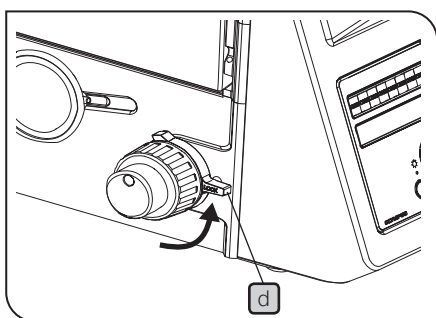

## 4-3 Stage

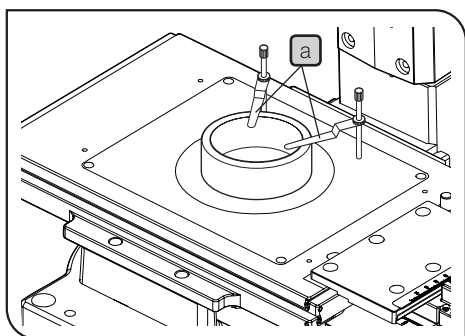

### 1 Placing the Specimen

Place the specimen on the center of the stage.

- Ⓞ If the specimen is prone to slide on the stage, attach the stage clips (IX-SCL) **a** and clamp the specimen down with the clips.

#### Stage (IX3-SVR, IX3-SVL)

For IX3-SVR, in addition to the holder for the round stage center plate, following sample holders corresponding to each sample can be attached.

- IX3-HOW-2 : Microplate holder
- IX3-HOS : Slide holder
- IX3-HO35D : Dish holder

See page 50 for assembly.

**CAUTION** The sample holder fixes the specimen to reproduce the specimen position. Do not push up the specimen by the objective lens. The specimen may be popped out.

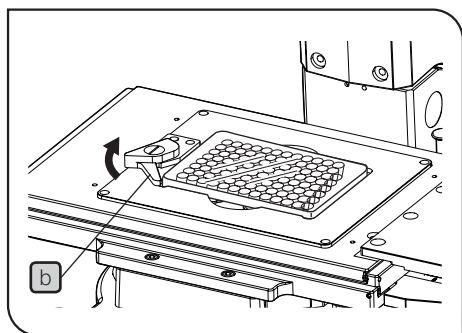

#### IX3-HOW-2

Open the specimen holder **b** of IX3-HOW-2, set the microplate in the center, push it toward the right diagonal direction, and return the specimen holder back to the original position.

«Mountable Microplate»

Microplate compliant with SLAS (ANSI/SBS Microplate Standards issued on Jan. 9, 2004.)

Size: 127.76 (plus or minus 0.5) x 85.48 (plus or minus 0.5) mm

Specimen holder: IX3-HOS, IX3-HO35D

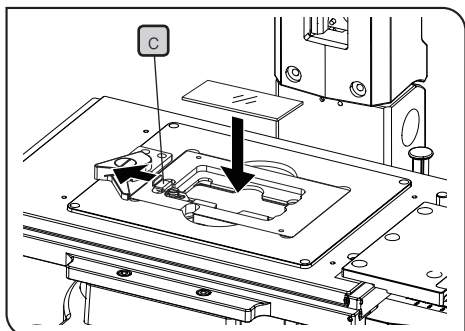

#### IX3-HOS

Open the specimen fixing part **c** of IX3-HOS outward, set the specimen in the center, push it toward the right diagonal direction, and return the specimen fixing part back to the original position.

«Chamber Slide Recommended»

- IWAKI Chamber Slide II (76 x 26 x 0.8 to 1.0 mm)
- Nunc Lab-Tek II Chamber Slide system (25 x 75 x 1.2 mm)
- BD Falcon CultureSlide (25 x 75 x 1.2 mm)

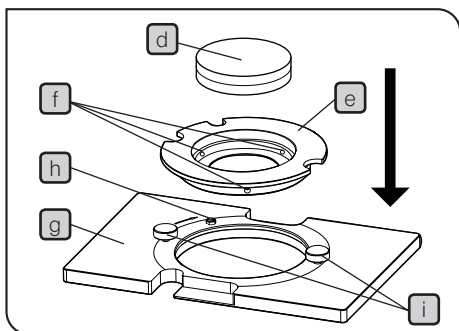

## IX3-HO35D

- 1 Place the 35 mm dish **d** on the 35 mm dish fixing holder **e**. Tighten the fixing screws **f** (3 screws) placed on the side with the Allen screwdriver provided with IX3-HO35D to secure the 35 mm dish.

Ⓞ The 35 mm dish can be secured easily by tightening the fixing screws after flipping over the 35 mm dish in advance.

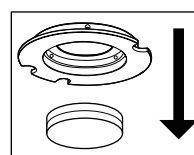

**CAUTION** Do not tighten the fixing screws too firmly. The dish may be damaged.

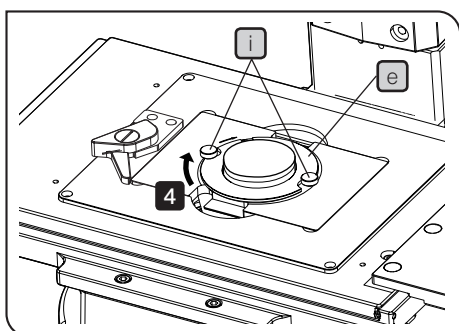

- 2 Set the fixing holder **e** in the center of IX3-HO35D **g** so that the cut-out meets the holder fixing knob **i**.
- 3 Loosen the holder fixing knobs **i**.
- 4 Rotate the fixing holder **e** clockwise to push it to the rotation stopper **h**.
- 5 Tighten the holder fixing knobs **i**.

Ⓞ The 35 mm dish fixing holder **e** can be sterilized by using the autoclave.

«35 mm Glass Bottom Dish Recommended»

- Matsunami Glass D111310
- MatTek P35GC-1.5-14-C

«35 mm Dish Recommended»

- BD Falcon 351008

Ⓞ You will be able to purchase only the 35 mm dish fixing holder **e**.  
(Product name : IX3-HOD35DF)

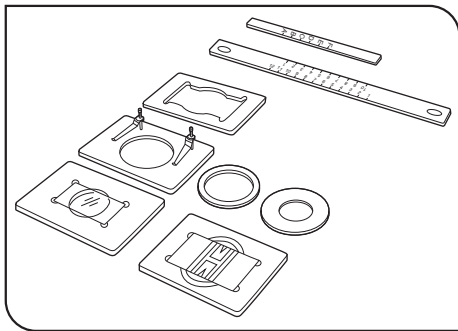
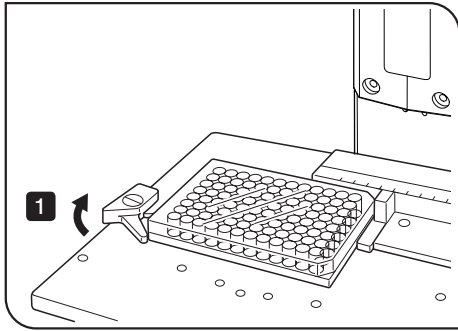

With the mechanical stage IX-MVR + stage IX2-SP

◎ 96-well or 24-well microplates, etc. are held in place by the specimen holder.

Microplates with dimensions of max. 136 mm x 92 mm can be accommodated in this way.

**1** Open the spring-loaded finger of the specimen holder 1 and slide the microplate into the holder frame. Gently release the curved finger to clamp.

◎ To secure other vessels than microplates, various optional holders are available. A Terasaki plate holder is available for holding Terasaki plates (72-well, 60-well). When using this, it is necessary to replace the stage scales with those provided with the plate holder. Dish holders are available for 35 mm, 54 mm and 65 mm diameter dishes, a slide glass holder is available for holding slide glass, and the IX2-BCTP\* is available for a blood cell test plate holder.

\* A blood cell test plate or other calculating chamber for bacteria and eosinophil with mounting section dimensions corresponding to H 77 x V 35 x D 2 mm can be used. A 60 mm diameter dish can also be used.

## 2 Moving the Specimen

- CAUTION**
- Do not attempt to rotate the stage handle forcibly exceeding the stage movable range. The stage may be damaged.
  - As the objective may interfere with the stage depending on the focus position, be sure to operate carefully.

### Scanning stage with ultrasonic (BX3-SSU)

The stage can be operated by the XY control or PC. For operating procedures, refer to the instruction manuals (BX3-SSU) provided separately or Help of PC (cellSens).

### With the mechanical handle stage (IX3-SVR, IX3-SVL)

To move the specimen to a desired position, rotate the X-axis knob **a** and Y-axis knob **b**.

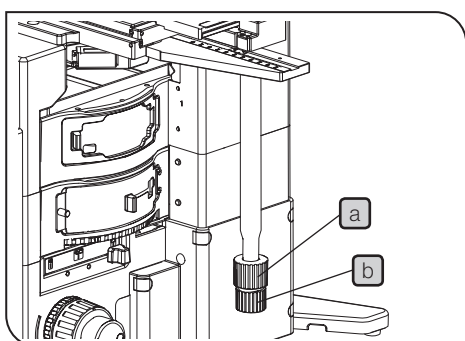

- ⊙ If the stage is used for a long time period, the stage movement range may be narrower rarely. In this case, move the stage several times within the full movement range toward the front/back or right/left direction while holding the top surface of the stage with both hands.

### Movement control knob

Attaching the movement control knob provided with IX3-SVR or IX3-SVL, makes it difficult to move the stage in the blocked direction. Even though you may touch the stage accidentally during observation, the observation position can be secured.

If the movement control knob is attached to the hole of **c**, the Y-axis movement will be blocked. If it is attached to the hole of **d** (backside of the stage), the X-axis movement will be blocked.

- CAUTION** Do not tighten the movement control knob too firmly. The stage may be damaged.

- ⊙ If you tighten the movement control knob while focusing on the specimen, it will be defocused.

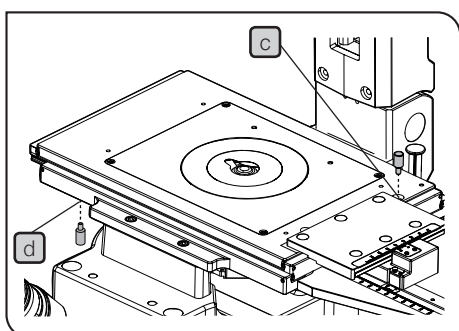

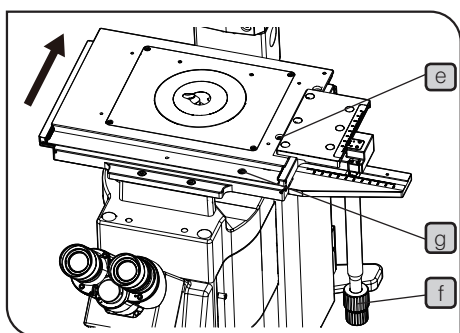

#### Movement range limit screw

As a factory default, IX3-SVR or IX3-SVL, is equipped with the movement range limit screw which limits the stage movable range in the vertical or horizontal direction.

To enlarge the movable range to observe microplates, etc., remove the movement range limit screw.

- 1 Remove the movement range limit screw **e** in the vertical direction with the Allen screwdriver provided with the microscope.
- 2 Rotate the longitudinal handle **f** to move the stage inward.
- 3 Remove the movement range limit screw **g** in the horizontal direction with the Allen screwdriver provided with the microscope.

#### Stage movable range

With movement range limit screw : 50 mm in vertical direction, 50 mm in horizontal direction

Without movement range limit screw: 75 mm in vertical direction, 114 mm in horizontal direction

**CAUTION** When using the center plate provided with IX3-SVR or IX3-SVL, attach the movement range limit screw.

If the movement range limit screw is not attached, the objective may hit the stage.

#### With the Mechanical Stage IX-MVR

To move the specimen to a desired position, rotate the X-axis knob and Y-axis knob in the same manner as IX3-SVR or IX3-SVL

© The stage travel area is 130 mm (X-axis) x 85 mm (Y-axis).

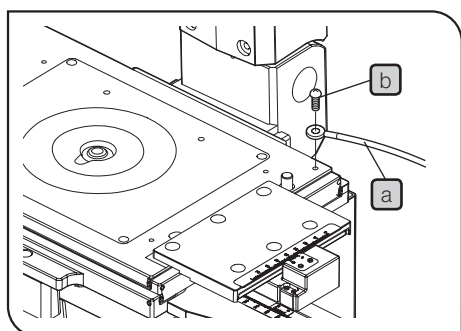

### 3 Connecting the Grounding Wire

#### With the Stage BX3-SSU, IX3-SVR or IX3-SVL

© A grounding wire can be attached to the stage for electrophysiological experiments, etc.

Prepare a grounding wire **a** and one M4 screw **b** and attach the grounding wire to a screw hole on the stage surface.

**CAUTION** The screw hole may sometimes be stuck by paint, etc. In such a case, screw in the M4 screw a few times to expose the metallic thread inside the screw hole and improve the contact before attaching the grounding wire firmly.



## 4-4 Observation Tube

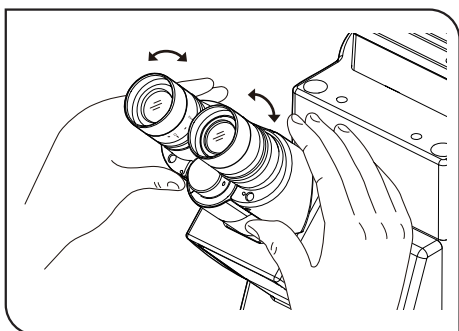

### 1 Adjusting the Interpupillary Distance

While looking through the eyepieces, adjust the binocular vision until the left and right fields of view coincide completely. The index dot • indicates the interpupillary distance.

- ⊙ Note your interpupillary distance so that it can be quickly duplicated

### 2 Adjusting the Diopter

- ⊙ The diopter adjustment makes it possible to reduce the specimen focusing error even after the objective is switched. As the diopter varies between individuals, the diopter adjustment is required for each person.

**CAUTION** The eyepiece with diopter adjustment ring should always be inserted into the observation tube without the diopter adjustment ring.

- 1 Set the diopter adjustment rings on both sides to scale "0".
- 2 Engage a high-power objective (e.g. 40X) in the light path, look into the right eyepiece with your right eye, and bring the sample into focus using the coarse/fine adjustment knob.

- ⊙ Do not use an immersion objective.

- 3 Engage a low-power objective (e.g. 10X) in the light path, rotate only the right diopter adjustment ring **a** to bring the sample into focus. At this time do not touch the coarse/fine adjustment knob.

- 4 Looking into the left eyepiece with your left eye, rotate only the left diopter adjustment ring **b** to bring the sample into focus.

- ⊙ The above procedure adjusts the diopter with reference to the right eye, but it is also possible to adjust with reference to the left eye. In this case, read the above procedure by inverting "right" and "left."

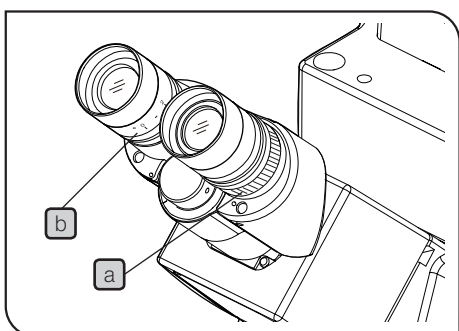

Using an eyepiece including a micrometer disk

- 1 Looking through the eyepiece with micrometer disk, turn the diopter adjustment ring **b** so that the micrometer in the field of view is sharply visible.
- 2 Looking through the eyepiece with micrometer disk, focus on the sample using the coarse/fine adjustment knob so that both the micrometer and sample are sharply visible.
- 3 Looking through the other eyepiece, turn only the diopter adjustment ring **a** to focus on the sample.

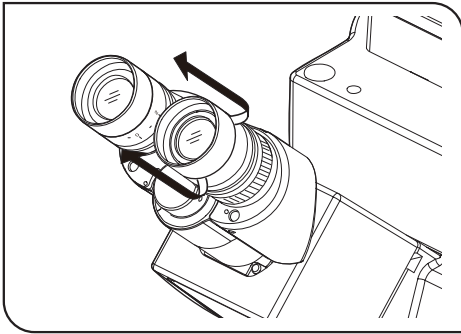

### 3 Using the Eye Shades

#### When wearing eyeglasses

Use the eye shades in the normal, folded-down position. This will prevent the eyeglasses from being scratched.

#### When not wearing eyeglasses

Extend the folded eye shades in the direction of the arrow to prevent extraneous light from entering between the eyepieces and eyes.

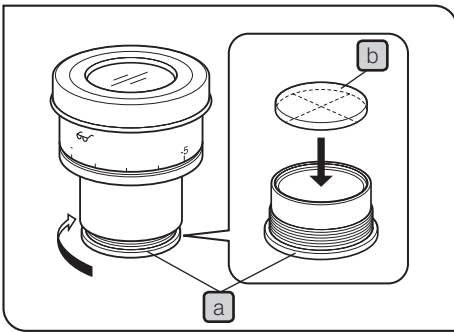

### 4 Mounting the Eyepiece Micrometer Disk

When the WHN10X-H eyepieces are used, an eyepiece micrometer disk can be mounted.

Use 24 mm dia. x 1.5 mm thick micrometer disks.

Turn the built-in micrometer-mounting frame **a** to the arrow direction (see figure) to remove it from the eyepiece and place a micrometer disk **b** into the mounting frame so that the surface with the model indication faces downward.

⊙ The micrometer-mounting frame may be too tight for certain micrometer disks.

In this case, turn the frame by holding the circumference with a light, uniform force or by applying the frame against a rubber sheet. Do not grasp the frame with a strong force, as this may deform the frame and make it harder to remove it.

Re-attach the micrometer mounting frame in the original position.

⊙ Be careful not to touch the lens or micrometer surface with your finger.

### 5 Selecting the Light Path of the Trinocular Tube

Slide the light path selector knob to select the desired light path.

(ex.) U-TR30-2, U-TR30H-2

Light path selector knob position		
Pushed in	Middle position	Pulled out
Observation 100%	Observation 20% Camera 80%	Camera 100%

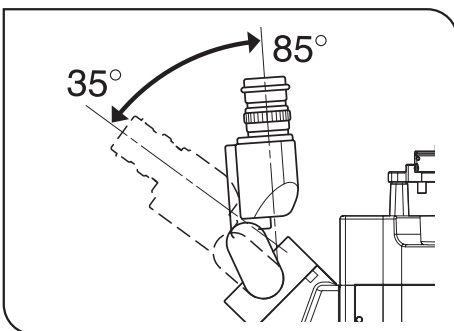

### 6 Adjusting the Tilt (U-TBI90)

⊙ Adjust the height and tilt of the eyepieces to obtain the most comfortable viewing position.

Holding the binocular section with both hands, adjust it to the desired position.

#### CAUTION

**Never attempt to force the binocular section past the upper or lower stop position. Applying excessive force could destroy the limiting mechanism.**

## 4-5 Illumination Column (IX3-ILL)

### 1 Tilting the Illumination Column

© When replacing large specimens, placing a micromanipulator or replacing a patch clamp electrode, working space can be created by tilting the illumination column.

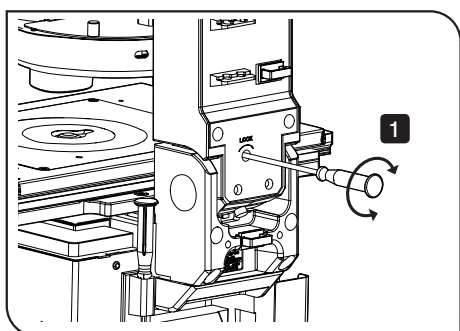

**1** Using the Allen screwdriver, turn the column tilt clamping screw to loosen it.

**2** Holding the illumination column's upper side and slowly tilt the illumination column until it stops. Vibrations should be avoided. Accordingly, always support the illumination column with a hand and tilt slowly and gently. To return the column to its original position, reverse this procedure.

#### CAUTION

- When tilting the illumination column upwards or downwards, make sure not to catch your fingers in the hinge joint.
- The tilt clamping screw should normally be tightened during use. If the microscope is used while the screw is loosened, make sure that the illumination column does not accidentally tilt during use.
- Do not stop the illumination column while tilting. The illumination column may fall toward the front side or back side.
- When moving or transporting the microscope, always do so with the tilt clamping screw tightened.
- If a heavy module such as a high-intensity lamp housing is installed, always use the microscope with the tilt clamping screw tightened.
- Do not turn ON the illumination lamp while the illumination column is tilted.

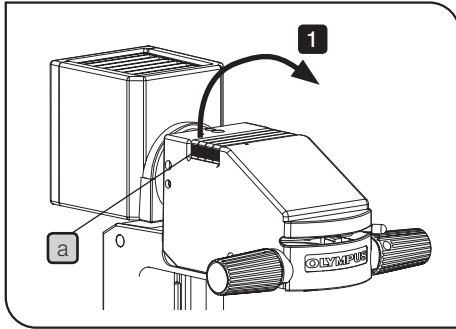

## 2 Mounting Filters

© 45 mm diameter, maximum 6 mm thick filters can be mounted. Various filters, such as the frost filter Ø45 mm (45FR), color temperature conversion filter (LBD), green interference filter (IF550) and ND filter can be mounted.

**1** Place a finger on the milled section **a** of the filter holder and lift it.

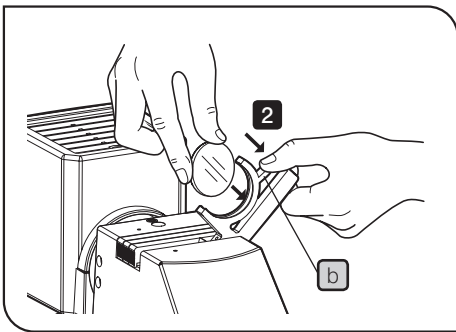

**2** While holding the mounting lever **b** of the filter holder, insert a filter.

### CAUTION

- Hold the filter by its edge to avoid leaving fingerprints or smudges on the filter surfaces.
- Shortly after the transmitted light illumination has been used, the filter will be very hot. Be sure to set the main switch to "O" (OFF) and allow the filter holder and filters to cool down before replacing filters.

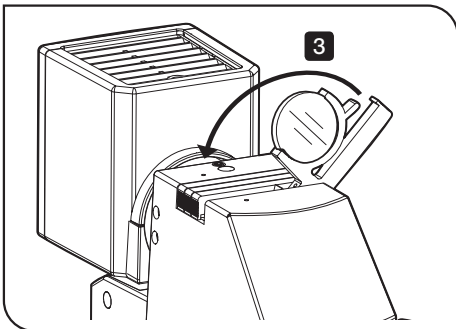

**3** Return the filter holder.

### CAUTION

- If the uneven brightness of the illumination light bothers you, we recommend engaging frost filter Ø45 mm (45FR), sold separately, in the light path.
- If the filter holder is open, you may be dazzled by the light leaked from the light source in some cases. We recommend closing the filter holder before using the microscope

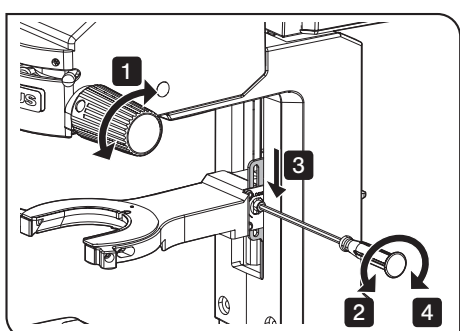
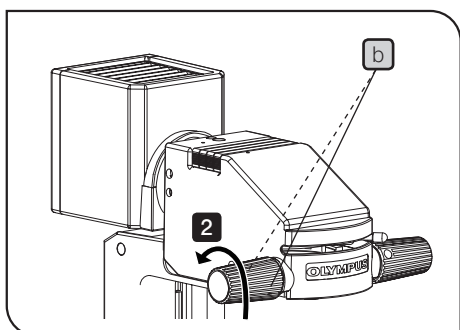
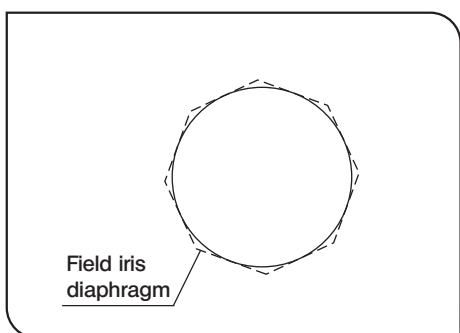
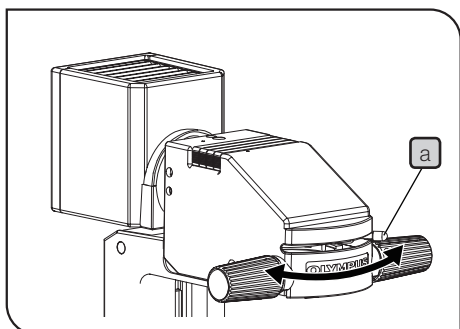

### 3 Using the Field Iris Diaphragm

⊙ The field iris diaphragm lever is used to adjust the diameter of the illumination beam in accordance with the objective in use. Adjust the diaphragm so that the field of view is circumscribed by the field iris diaphragm to cut extra light and improve the contrast of images.

- 1 Move the field iris diaphragm lever **a** to the left or right to close or open the diaphragm.

○ : Direction for opening the diaphragm

⊙ : Direction for closing the diaphragm

### 4 Adjusting the Condenser Height Adjustment Knob Tension

- 1 Loosen the two knob clamping screws **b** on the left adjustment knob using the Allen screwdriver.
- 2 While holding the right adjustment knob not to rotate it, turning the left adjustment knob counterclockwise (in the direction of the arrow) decreases the rotation tension and clockwise increases it. Rotating the right adjustment knob allows adjusting the tension of the condenser height adjustment knob while checking it.
- 3 After adjustment, tighten the two knob clamping screws **b** securely.

### 5 Condenser refocusing stopper

A mechanism returns the condenser back to the original position easily after moving the condenser.

⊙ To use the condenser refocusing stopper, refer to page 57 , and attach the condenser refocusing stopper before use.

- 1 Bring the field diaphragm image into focus by rotating the condenser height adjustment knob.
- 2 Loosen the clamping screws of the stopper using the Allen screwdriver provided with the microscope.
- 3 Push the top of the stopper downward so that the stopper contacts the column securely.
- 4 Tighten the clamping screws of the stopper using the Allen screwdriver provided with the microscope.

**CAUTION** Rotating the condenser height adjustment knob beyond the condenser height adjustment area with an excessive force could damage the microscope. Pay careful attention when rotating it.

⊙ If the manipulator is assembled to the column, the Allen screwdriver provided with the microscope may not be used in some cases.

## 4-6 Condenser

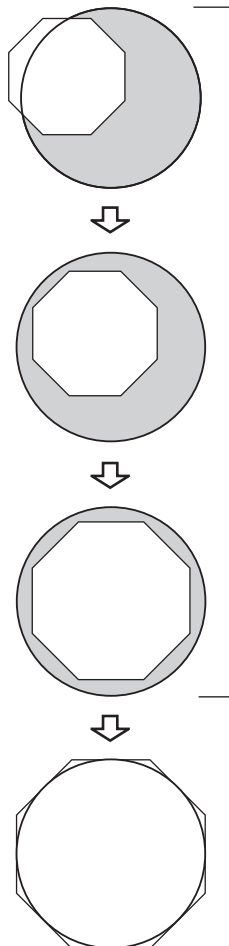
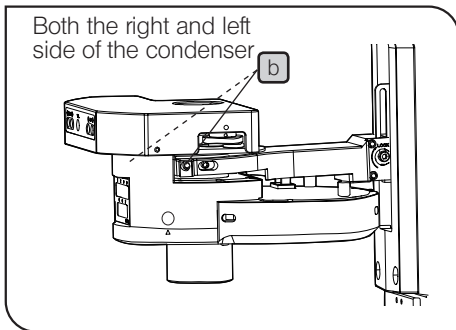
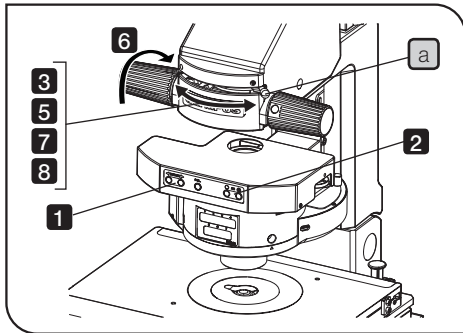

### 1 Centering the Condenser

With the Condenser (IX3-LWUCDA, IX2-LWUCD, IX-ULWCD, IX2-MLWCD or IX3-MLWCDA)

- 1 Rotate the turret (either manually or electrically) to select the "BF" brightfield observation (with which no optical element is engaged in the light path).
- 2 Move the aperture iris diaphragm lever to open the diaphragm.
- 3 Move the field iris diaphragm lever **a** to the fully open position (⊗ → ○).
- 4 Engage the 10X objective and bring the specimen into focus.
- 5 Using the field iris diaphragm lever **a**, stop down the field iris diaphragm until its image is just inside the field of view.
- 6 Rotate the condenser height adjustment knob to bring the field iris diaphragm image into focus.
- 7 While gradually opening the field iris diaphragm lever **a**, install the Allen screwdriver provided with the microscope in the adjustment hole **b** and rotate it so that the field iris diaphragm image is centered in the field of view of the eyepieces.
- 8 To check centration, open the field iris diaphragm lever **a** until its image inscribes the field of view. Now the condenser is centered.

In actual observation, open the field iris diaphragm until its image circumscribes the field of view.

#### Effect of Field Iris Diaphragm

This is the iris diaphragm to adjust the area to be illuminated. By narrowing down to the level circumscribing the field of view depending on objectives, the excess light can be shielded to acquire the image with good contrast.

- ⊗ Depending on the condenser to be used, the field iris diaphragm may not be viewed by the objective of 40X or higher magnification.

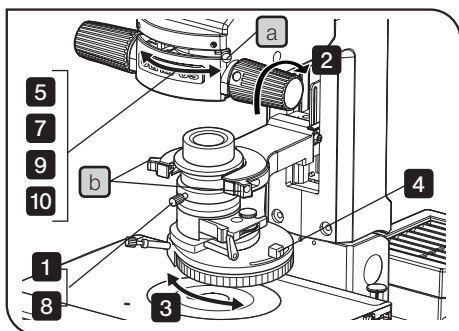

With the U-UCD8 Condenser

- 1** Rotate the condenser height fine adjustment knob counterclockwise to loosen it, then push the knob all the way toward the rear.
- 2** Rotate the condenser height adjustment knob in the direction of the arrow to lower the condenser to the level not to hit the specimen.
- 3** Rotate the turret to select the "BF" brightfield observation (with which no optical element is engaged in the light path).
- 4** Move the aperture iris diaphragm lever to open the diaphragm.
- 5** Move the field iris diaphragm lever **a** to the fully open position (⊗ → ○).
- 6** Engage the 10X objective and bring the specimen into focus.
- 7** While gradually opening the field iris diaphragm lever **a**, install the Allen screwdriver provided with the microscope in the adjustment hole and rotate it so that the field iris diaphragm image is centered in the field of view of the eyepieces.
- 8** Slowly move the condenser height fine adjustment knob toward the front to bring the field iris diaphragm image into focus. When focusing is obtained, rotate the knob clockwise to clamp it.
- 9** While gradually opening the field iris diaphragm lever **a**, install the Allen screwdriver provided with the microscope in the adjustment hole **b** and rotate it so that the field iris diaphragm image is centered in the field of view of the eyepieces.
- 10** To check centration, open the field iris diaphragm lever **a** until its image inscribes the field of view. Now the condenser is centered.
  - ⊙ In actual observation, open the field iris diaphragm until its image circumscribes the field of view.
  - ⊙ When replacing the specimen or spreading immersion oil, use the condenser height adjustment knob to raise the condenser first. After finishing the procedure, lower the condenser to its lowest position.

## 2 Using the Aperture Iris Diaphragm

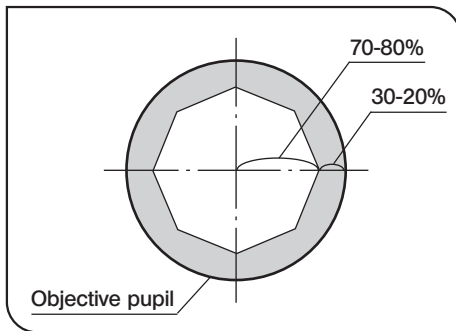

- ⊙ In general, the potential resolving power of an objective is fully utilized if the diaphragm is stopped down to correspond with the numerical aperture (NA) of the objective.
- ⊙ Depending on the specimen, image contrast or focal depth in observation or acquisition may be improved by keeping the aperture iris diaphragm stopped down a little. In general, a good image is obtained if the diaphragm is stopped down to between 70% and 80% of the NA. of the objective. Stop further down for less contrasty specimens.
- ⊙ To check the position of the perimeter of the aperture iris diaphragm, remove the eyepieces and look into the eyepiece sleeves to view the aperture iris diaphragm image and the objective's exit pupil.



## 4-7 Oil- or Water-Immersion Objective

### 1 Using Oil- or Water-Immersion Objective

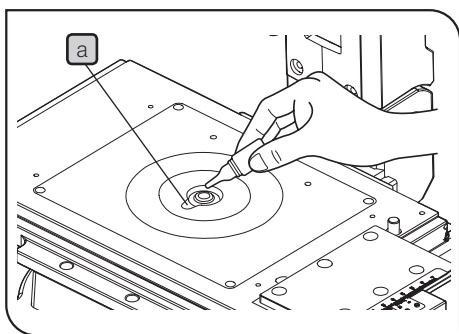

⊙ If you use an oil-immersion objective, use immersion oil as described below.

**CAUTION** Always use immersion oil supplied by Olympus.

- 1 Using a low-power objective, bring the specimen into focus.
- 2 Rotate the revolving nosepiece to engage the oil immersion objective.
- 3 Remove the specimen and move the stage insert cut-out **a** close to the objective front lens. Apply a drop of the immersion oil to the objective front lens. Place the specimen and rotate the fine adjustment knob to bring the specimen into focus.

**CAUTION**

- Use as little oil as possible.
- If the oil contains air bubbles, the image will be degraded. Make sure the oil is free of air bubbles.

- 4 After use, remove immersion oil from the objective front lens by wiping with gauze slightly moistened with absolute alcohol.

⊙ The presence of air bubbles can be checked by viewing the pupil of the objective (viewed as a bright circular shape) in the tube after removing the eyepiece and opening the field iris diaphragm and the aperture iris diaphragm completely.

**CAUTION** Caution in use of immersion oil:

If immersion oil enters your eyes or contacts your skin, immediately take the following treatment.

Eyes: Rinse with fresh water (for 15 minutes or more).

Skin : Rinse with water and soap.

If the appearance of the eyes or skin is altered or pain persists, immediately see your doctor.

## 4-8 Objectives with Correction Collar

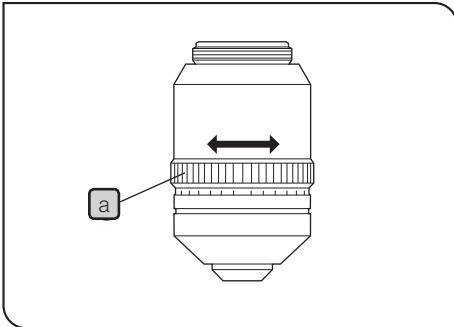

⊙ If the thickness of the cover glass or the vessel does not match the thickness scale of an objective with correction collar, the objective cannot manifest its performance. When using a correction collar equipped objective, perform the following adjustment as required.

### Adjustment Procedure

- If the cover glass thickness is known, set the correction collar **a** to that value on the scale.
  - If the cover glass thickness is unknown, adjust the correction collar **a** and rotate the fine adjustment knob alternately until the positioning with the highest contrast is obtained.
- ⊙ Be careful not to touch the correction collar **a** when turning the revolving nosepiece.

# 5 OTHER OBSERVATION METHODS

## 5-1 Phase Contrast Observation

- ⊙ A phase contrast objective, phase contrast optical element, and the U-CT30-2 centering telescope are required for phase contrast observation.
- ⊙ If a DIC slider, analyzer or polarizer is engaged in the light path, disengage it.

### 1 Phase Contrast Optical Elements and Applicable Objectives

With the IX3-LWUCDA or IX2-LWUCD

- ⊙ Insert the optical element (small) in the 30 mm position and the optical element (large) in the 38 mm position.  
When observing the specimens in wells, it is recommended to use the IX-PHC to obtain the phase contrast effect in a wide range of field of view.

Optical Element	Indication	Applicable Objectives
IX-PHL (small)	PhL	UPLFLN4XPH
IX-PHC (small)	PhC	CPLN10XPH, LCACHN20XPH, CPLFLN10XPH
IX-PH1 (small)	Ph1	UPLFLN10X2PH, UPLFLN20XPH, LUCPLFLN20XPH
IX-PH2 (small)	Ph2	UCPLFLN20XPH, UPLFLN40XPH, LUCPLFLN40XPH, LUCPLFLN60XPH, LCACHN40XPH
IX-PH3 (large)	Ph3	PLAPON60XOPH, UPLFLN60XOIPH, UPLSAPO100XOPH, UPLFLN100XO2PH

Example of attaching optical elements (IX3-LWUCDA)

Small Diameter: PH1, PHL, free or PH2, C, free

Large Diameter: PH3, DIC40, DIC60, DIC100

With the IX-ULWCD

- ⊙ The IX-PHCU or IX-PH1U can be attached only in the Ph1 and PhC. (Do not remove the built-in elements.)

Optical Element	Indication	Applicable Objectives
PHL (built-in)	PhL	UPLFLN4XPH
IX-PHCU	PhC	CPLN10XPH, LCACHN20XPH, CPLFLN10XPH
IX-PH1U	Ph1	UPLFLN10XPH, UPLFLN20XPH, LUCPLFLN20XPH,
PH2 (built-in)	Ph2	UCPLFLN20XPH, UPLFLN40XPH, LUCPLFLN40XPH, LUCPLFLN60XPH, LCACHN40XPH

- ⊙ When using the U-UCD8, IX2-MLWCD, or IX3-MLWCDA, refer to the provided instructions.

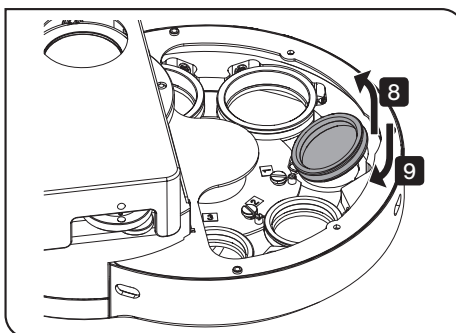
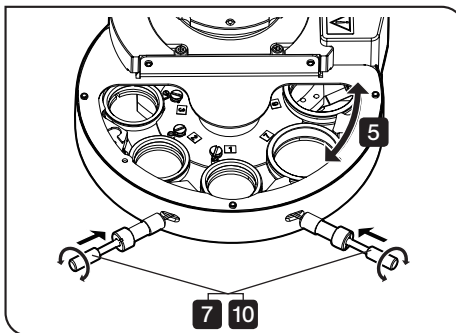
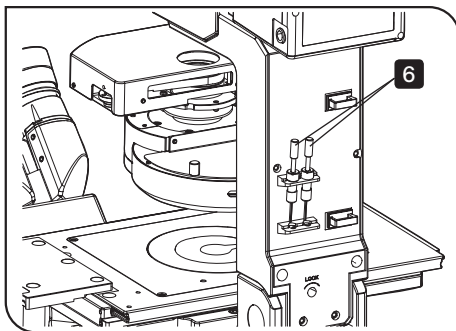
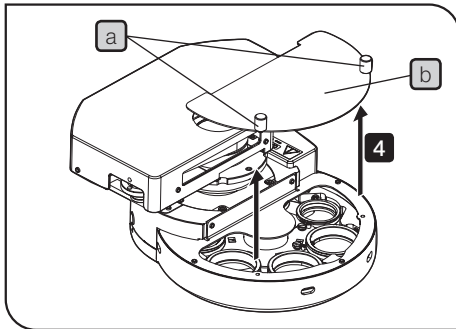

## 2 Attaching the Phase Contrast Optical Elements

With the IX3-LWUCDA

- ⊙ As a factory default, the dummy element is in the turret hole. Keep the dummy element in a safe place because it will be used again when the microscope is transported next time.
- ⊙ In general, the turret No.[7] is defined as the bright field (BF) position, and the dummy element remains in the turret hole.

- 1 Turn "O" OFF the IX3-CBM.
- 2 Remove the connector of the condenser from IX3-CBM.
- 3 Remove the condenser from the column (page 58).
- 4 Loosen the two clamping screws **a** and remove the top cover **b**.
- 5 Rotate the turret so that the turret holes to insert the optical elements come to the center.
- 6 Take out the condenser centering knobs (2 knobs) from the storage area on the back side of the illumination column.
- 7 Insert the condenser centering knobs, and loosen the optical element fixing screw while pushing the knob.
- 8 Hold a phase contrast ring (the dummy element when using this system for the first time), and while lightly pushing toward the direction where the spring inside the turret is attached, hold the ring up slowly and remove it from the opposite side of the spring.
- 9 Attach the phase contrast ring to be used to the turret hole by pushing it to the spring inside the turret.
- 10 Tighten the optical element fixing screw by using the condenser centering knobs.

### CAUTION

- Be careful not to apply pressure to the ring slit inside the frame.
- If the optical element centering knobs are attached, the turret is unable to be rotated.
- If the optical element fixing screws are loosened, the fixing screws will interfere while rotating the turret. Be sure to tighten the screws firmly. Do not tighten the optical element centering knobs too much, this may deform the frames of the optical elements.
- When using the IX3-LWUCDA, make sure to place the dummy elements in the turret holes where any optical elements are not engaged. If the dummy elements are not placed, the centering devices in the turret holes may drop off inside of the turret by the vibration of continuous rotation of the turret.

- 11 When all of the required optical elements have been mounted, attach the cover and tighten the detaching screws.
- 12 Attach the condenser to the column and connect the connector of the condenser to IX3-CBM.
- 13 Turn "I" ON the power in the sequence of PC, IX3-CBM and Touch Panel Controller. (The turret position of the condenser will be initialized.)

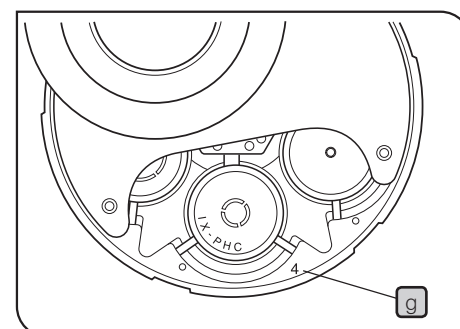
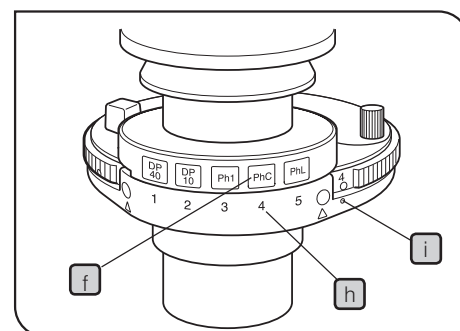
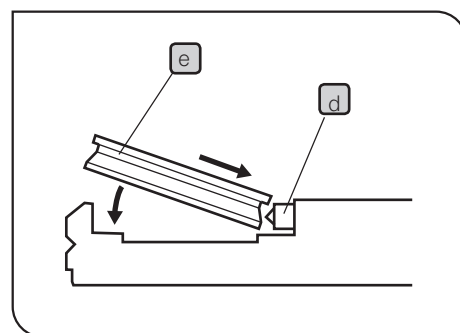
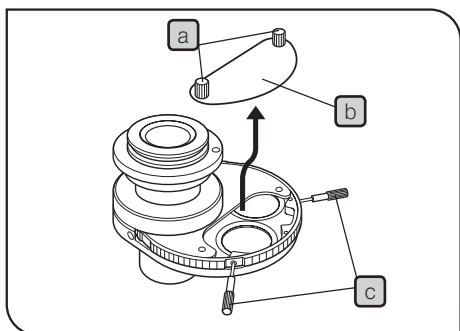

With the IX2-LWUCD, IX-ULWCD

⊙ Do not engage any optical element in the BF (brightfield) light path.

- 1 Place the condenser in a direction of left-hand figure, loosen the detaching screw **a** and remove the cover **b**.
- 2 Rotate the turret so that the number of the next optical element to be inserted in the uncovered position is visible.
- 3 Loosen the optical element position centering screws using the optical element centering knobs **c**.
- 4 Hold a phase contrast ring and, while pushing the spring **d** inside the turret with the edge of the phase contrast ring **e**, insert the ring completely in the turret position until the ring frame contacts the bottom of the position.
- 5 Rotate the optical element centering knobs clockwise to tighten the centering screws lightly.
- 6 Place the index **f** provided with each optical element in the index insertion hole having the same number **h** as the number of the position **g** in which the corresponding optical element is mounted. (IX-ULWCD does not have the index.)

⊙ The optical element with the number indicated by marking **i** is engaged in the light path.

- 7 When all of the required optical elements have been mounted, attach the cover and tighten the detaching screws.

**CAUTION**

- Be careful not to apply pressure to the ring slit inside the frame.
- If the optical element centering knobs are attached, the turret is unable to be rotated.
- If the optical element fixing screws are loosened, the fixing screws will interfere while rotating the turret. Be sure to tighten the screws firmly. Do not tighten the optical element centering knobs too much, this may deform the frames of the optical elements.
- To remove an optical element index, use the tip of a ball-point pen or mechanical pencil.

With the U-UCD8, IX2-MLWUCD or IX3-MLWCDA

⊙ Refer to the provided instructions.

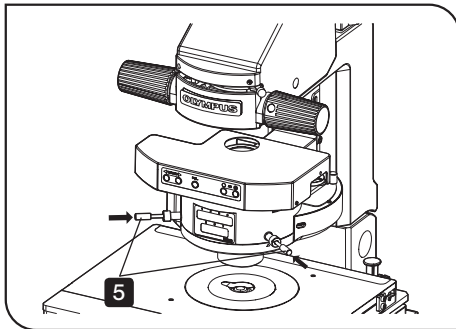
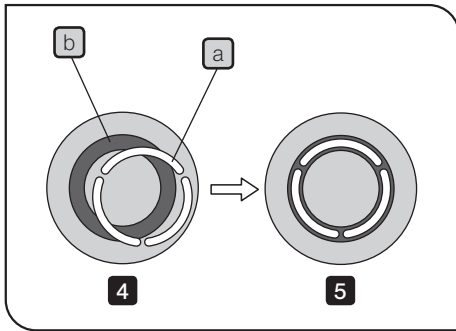

### 3 Centering the Phase Contrast Ring Slit

⊙ Open the aperture iris diaphragm during phase contrast observation.

- 1 Engage the phase contrast objective in the light path and bring the specimen into focus.
- 2 Remove an eyepiece and attach the U-CT30-2 centering telescope in place.
- 3 Engage the ring slit of the condenser matching the phase contrast objective in the light path.
- 4 Rotate the knurled section of the centering telescope to focus on the ring slit **a** and the phase plate **b** of the objective.
- 5 Pushing the optical element centering knobs, turn the phase contrast ring slit centering screws (in positions marked) so that the ring slit image overlaps with the phase plate of the objective.

⊙ Do not release the hand suddenly while the optical element centering knobs are being pushed in. The optical element centering knobs may be popped out.

- 6 Remove the U-CT30-2 centering telescope and attach an eyepiece in place.

⊙ If the vessel is not completely flat, it may become necessary to adjust the centering again to obtain the optimum contrast. Adjust the centering in each objective power.

- 7 Adjust the field iris diaphragm so that its image circumscribes the field of view and observe the phase contrast.

⊙ Engaging the green filter in the light path will improve the contrast.

## 5-2 Differential Interference Contrast Observation

- Ⓞ If a plastic dish is used, the normal optical performance of DIC observation cannot be manifested due to the polarization characteristic of the dish. Use a glass dish.
- Ⓞ For simultaneous observation with reflected fluorescence observation, refer to the separate instruction manual.
- Ⓞ DIC optical elements, a DIC slider, analyzer, and polarizer are required for DIC observation.

### 1 DIC Optical Elements, Applicable Objectives and DIC Sliders

With the IX3-LWUCDA or IX2-LWUCD

- Ⓞ Insert a small optical element (one of the optical elements inside ( ) in the following table) in the 30 mm position and other optical element (large) in the 38 mm position.

UIS2 Series

Applicable Objective	DIC Slider	U-DICT	U-DICTS/IX3-DICTA Shift Type	U-DICTHC High Contrast Type	U-DICTHR High Resolution Type
UPLSAPO	10X2	( IX2-DIC10 )	( IX2-DIC10 )	-	-
	20X	( IX2-DIC20 )	( IX2-DIC20 )	( IX2-DIC20HC )	( IX2-DIC20HR )
	20XO	( IX2-DIC20 )	( IX2-DIC20 )	( IX2-DIC20HC )	( IX2-DIC20HR )
	30XS	IX2-DIC30	IX2-DIC30	-	-
	40X2	IX2-DIC40	IX2-DIC40	IX2-DIC40HC	IX2-DIC40HR
	40XS	-	IX2-DIC40	IX2-DIC40HC	IX2-DIC40HR
	60XO	-	IX2-DIC60	-	-
	60XW	IX2-DIC60	IX2-DIC60	-	-
	60XS	IX2-DIC60	IX2-DIC60	-	-
	100XO	IX2-DIC100	IX2-DIC100	-	-
100XOPH	IX2-DIC100	IX2-DIC100	-	-	
PLAPON	60XO	-	IX2-DIC60	-	-
	60XOSC2	-	IX2-DIC60	-	-
	60XOPH	-	IX2-DIC60	-	-
UPLFLN	10X2	( IX2-DIC10 )	( IX2-DIC10 )	-	-
	20X	( IX2-DIC20 )	( IX2-DIC20 )	( IX2-DIC20 )	( IX2-DIC20HR )
	40X	IX2-DIC40	IX2-DIC40	IX2-DIC40HC	IX2-DIC40HR
	40XO	-	IX2-DIC40	IX2-DIC40HC	IX2-DIC40HR
	60X	IX2-DIC60	IX2-DIC60	-	-
	60XOI	IX2-DIC60	IX2-DIC60	-	-
	100XO2	IX2-DIC100	IX2-DIC100	-	-
	100XOI2	IX2-DIC100	IX2-DIC100	-	-
LUCPLFLN	20X	( IX2-DIC20 )	( IX2-DIC20 )	( IX2-DIC20HC )	( IX2-DIC20HR )
	40X	IX2-DIC40	IX2-DIC40	IX2-DIC40HC	IX2-DIC40HR
	60X	IX2-DIC60	IX2-DIC60	-	-
UAPON	20XW340	( IX2-DIC20 )	( IX2-DIC20 )	( IX2-DIC20HC )	( IX2-DIC20HR )
	40XW340	-	IX2-DIC40	IX2-DIC40HC	IX2-DIC40HR
	40XO340-2	-	IX2-DIC40	IX2-DIC40HC	-
	40XO340	-	IX2-DIC40	IX2-DIC40HC	IX2-DIC40HR
	100XOTIRF	IX2-DIC100	IX2-DIC100	-	-
	150XOTIRF	IX2-DIC100	IX2-DIC100	-	-
UCPLFLN	20X	( IX2-DIC20 )	( IX2-DIC20 )	( IX2-DIC20HC )	( IX2-DIC20HR )
	20XPH	( IX2-DIC20 )	( IX2-DIC20 )	( IX2-DIC20HC )	( IX2-DIC20HR )
APON	60XOTIRF	-	IX2-DIC60	-	-
	100XHOTIRF	-	IX2-DIC100	-	-

- Ⓞ When using the U-UCD8 or IX3-MLWCDA, refer to the provided instructions.

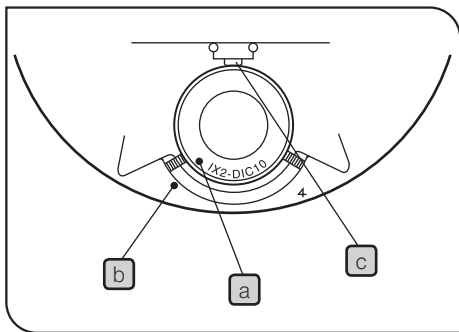

## 2 Attaching the DIC Optical Elements

◎ The attaching method is identical to that for the phase contrast optical elements (page 34), except that the positioning pin and positioning groove should be aligned when attaching each DIC optical element.

Align the positioning index **a** on the DIC prism with the positioning index **b** on a turret position and insert the DIC prism all the way into the turret position so that the DIC prism's frame hits the bottom of the position and the prism's positioning pin fits into the pin hole. When inserting, push the spring **c** inside the turret slightly sideward.

### CAUTION

- Be careful not to touch the DIC prism area inside the frame.
- Do not tighten the optical element centering knobs too much, for this may deform the frame of the optical element.
- Set the main switch to "O" (OFF) of the IX3-CBM, replace the optical element of the motorized condenser. If the optical element is replaced while the main switch set to "I" (ON), restart the microscope.



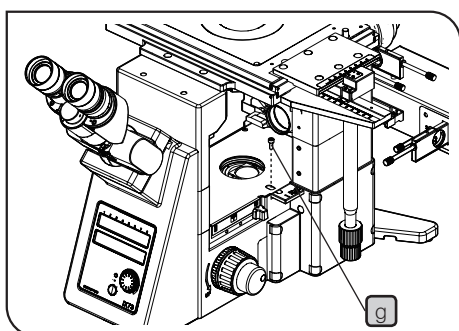
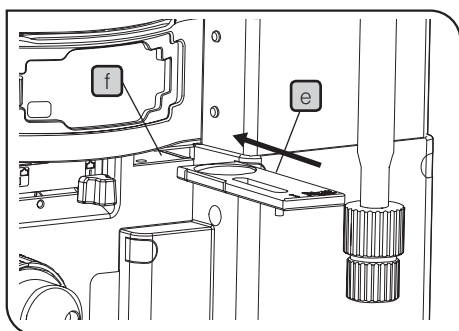
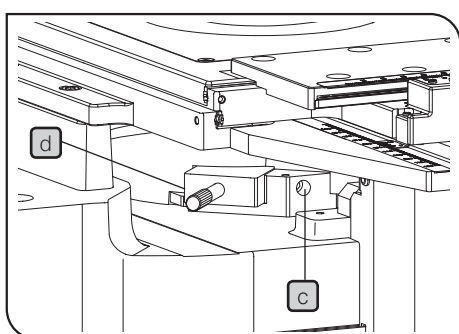
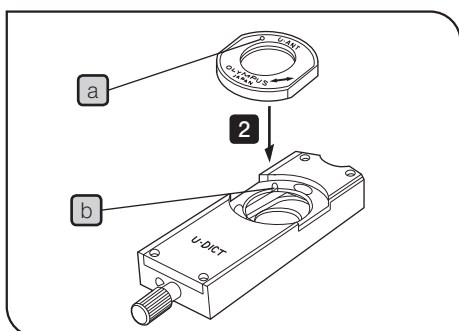

### 3 Attaching the Analyzer and DIC Slider

#### With the U-DICT DIC Slider

- 1 Align the index **a** of the U-ANT analyzer and the positioning groove **b** of the U-DICT DIC slider and drop the analyzer into the analyzer mount of the DIC slider.
- 2 Loosen the fixing screw **c** by using the Allen screwdriver provided with the microscope to remove the dummy slider from the revolving nosepiece.
- 3 Hold the U-DICT **d** so that the side with indication faces down, insert it into the revolving nosepiece.

#### With the DIC Slider U-DICTS/U-DICTHC/U-DICTHR

⊙ If you use these sliders, the analyzer U-ANT cannot be used. The transmitted DIC mirror unit IX3-FDICT or the analyzer slider IX3-AN is required.

- 1 Loosen the fixing screw **c** by using the Allen screwdriver provided with the microscope to remove the dummy slider from the revolving nosepiece.
- 2 Insert the DIC slider to be used into the revolving nosepiece by facing its display surface down.

#### With the motorized DIC slider IX3-DICTA

⊙ For details, read the instruction manual for the IX3-DICTA.

#### With the Transmitted DIC Mirror Unit IX3-FDICT

IX3-FDICT is the mirror unit equipped with the analyzer. This is attached to the mirror unit cassette and engaged into the light path during the transmitted differential interference observation.

In this case, it is not necessary to attach the analyzer U-ANT to U-DICT.

⊙ For the procedure for attaching IX3-FDICT to the mirror unit cassette, refer to the separate instruction manual entitled "Reflected Fluorescence System".

#### Analyzer slider IX3-AN

- 1 Hold the analyzer slider IX3-AN **e** so that the side with indication faces up, and insert the analyzer into the analyzer insertion slot **f** until it clicks.
- ⊙ After the analyzer is attached to the microscope, attaching the stopper screw **g** provided with IX3-AN to the microscope by using the Allen screwdriver will prevent the detachment of the analyzer. In such a case, the fluorescence illuminator or the fluorescence mirror turret must be removed.

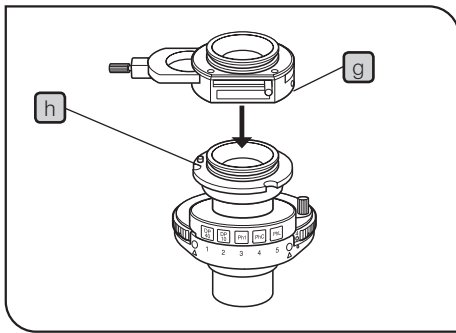

#### 4 Attaching the Polarizer (IX-LWPO)

**CAUTION** The polarizer can be mounted only on the IX2-LWUCD.

⊙ This polarizer has been designed for being mounted on the IX2-LWUCD in case of DIC observation or simplified polarizer light observation.

- 1 Loosen the polarizer clamping screw **g** using the Allen screwdriver.
- 2 Align the pin hole on the condenser with the positioning pin **h** on the condenser, and insert the polarizer unit into the upper part of the condenser.
- 3 Tighten the polarizer clamping screw firmly.

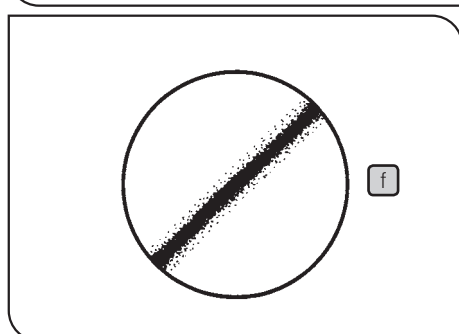
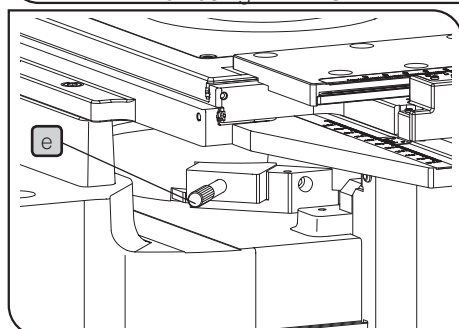
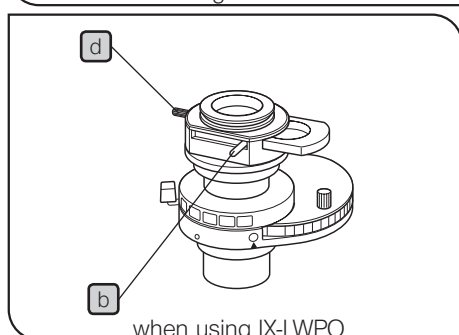
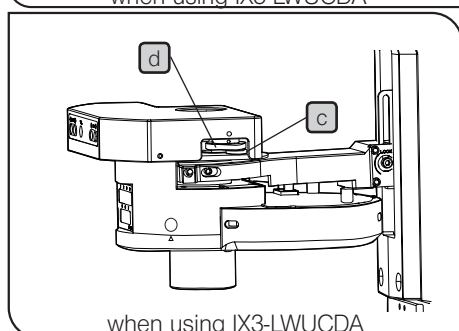
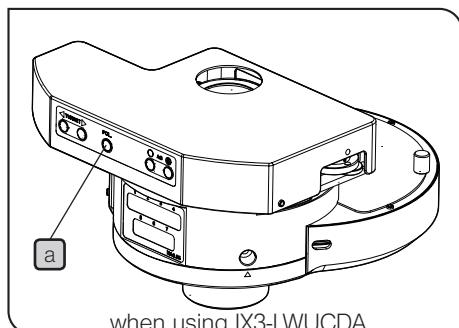

## 5 Cross-Nicol Adjustment

- 1 Rotate the condenser's turret for the BF (brightfield) light path (with no optical element engaged in the light path).
- 2 When IX3-LWUCDA is used, push the button **a** of IX3-LWUCDA to engage the polarizer in the light path.  
When IX-LWPO is used, move the polarizer detaching lever **b** on the IX-LWPO polarizer to engage the polarizer in the light path.

- 3 Engage the 10X objective in the light path, place an optimum specimen for brightfield observation on the stage, bring the specimen into approximate and remove the specimen out of the light path.

- 4 Refer to page 39, engage the DIC slider and the analyzer in the light path.

- 5 Remove the eyepieces from the observation tube, look into the observation tube.

- 6 Move the prism movement knob **e** of the DIC slider in the clockwise direction around the axis until the knob is stopped. First a black interference stripe then a rainbow-colored interference stripe will be observed. Stop the knob at the position in which the black interference stripe can be seen. (State of **f**)

- 7 When IX3-LWUCDA is used, loosen the polarizer rotation knob **d** by rotating the clamping knob **c** in the clockwise direction until the knob stops.

When IX-LWPO is used, loosen the clamping of the polarizer rotation/clamping knob by rotating slightly the polarizer rotation/clamping knob **d** in a counter-clockwise direction.

- 8 While looking into the observation tube, rotate the polarizer rotation/clamping knob **d** on the polarizer unit horizontally until the black interference stripe becomes darkest. This is the cross-nicol position.

- 9 After determining the position, clamp the polarizer.

When the IX3-LWUCDA is used, rotate the clamping knob **c** in the counterclockwise direction around the axis until the knob is stopped.

When the IX-LWPO is used, rotate the polarizer rotation/clamping knob **d** in a clockwise direction until the knob stops.

## 6 Observation Method

- 1 Rotate the condenser turret to engage the suitable optical element for the objective in use in the light path.
- 2 Engage the objective to be used in the light path.
- 3 Place the specimen on the stage and bring the specimen into focus by moving the objective up or down.
- 4 Adjust the field iris diaphragm so that its image circumscribes the field of view.
- 5 Adjust the aperture iris diaphragm to enhance the contrast.
- 6 Engage the DIC slider in the light path.
- 7 Move the prism movement knob of the DIC slider to select the interference color that can provide the optimum contrast in accordance with the specimen.

U-DICT :            The background interference color is continuously variable from the gray sensitive color to purple sensitive color.

U-DICTS :        }  
U-DICTHC :       } The background interference color is continuously variable from black to light gray.  
U-DICTHR :       }

© With sensitive color observation using the U-UCD8, engage the UUCDTP530 1 plate (sensitive color plate) in the light path.

- Setting the background color to dark enables an observation like darkfield observation.
- Setting the background color to gray provides observation with high contrast and 3D feeling with the gray sensitive color with which the sensitivity is highest.
- Setting the background color to gray allows very small change in phase to be observed as a change in color.
- There is a directional characteristic with the detection sensitivity because of the configuration of the DIC prism. As a result, the contrast may sometimes be improved by rotating the specimen on the stage.

### CAUTION

For simultaneous observation with reflected fluorescence observation, refer to the instruction manual entitled "REFLECTED FLUORESCENCE SYSTEM".

## 5-3 Simplified Polarized Light Observation

### 1 Attaching the Analyzer and Polarizer

- ⊙ Use the same procedure as that for attaching the analyzer and polarizer for DIC observation.
- ⊙ The simplified polarized light observation is enabled also by attaching the analyzer U-ANT to the dummy slider.
- ⊙ If a plastic dish is used, the normal optical performance of DIC observation cannot be manifested due to the polarization characteristic of the dish. Use a glass dish.

### 2 Observation Method

- 1 Rotate the turret for the BF (brightfield) light path (with no optical element engaged in the light path).
- 2 When IX3-LWUCDA is used, push the button **a** of IX3-LWUCDA to engage the polarizer in the light path.  
When IX-LWPO is used, move the polarizer detaching lever **b** on the IX-LWPO polarizer to engage the polarizer in the light path.
- 3 Rotate the revolving nosepiece to engage the objective to be used in the light path.
- 4 Refer to page 39 and engage the analyzer in the light path.
- 5 When IX3-LWUCDA is used, loosen the polarizer rotation knob **d** by rotating the clamping knob **c** in the clockwise direction until the knob stops.  
When IX-LWPO is used, loosen the clamping of the polarizer rotation/clamping knob by rotating slightly the polarizer rotation/clamping knob **d** in a counter-clockwise direction.
- 6 Move the polarizer rotation/clamping knob **d** on the polarizer unit horizontally in the counterclockwise direction around the axis until the position in which the field of view is darkest.
- 7 After determining the position, clamp the polarizer.  
When the IX3-LWUCDA is used, rotate the clamping knob **c** in the counterclockwise direction around the axis until the knob is stopped.  
When the IX-LWPO is used, rotate the polarizer rotation/clamping knob **d** in a clockwise direction until the knob stops.
- 8 Place a specimen on the stage and bring the specimen into focus. Now the specimen can be observed with simplified polarized light observation.
- 9 Adjust the field iris diaphragm so that its image circumscribes the field of view.
- 10 Adjust the aperture iris diaphragm to enhance the contrast.
  - ⊙ If you use 1.6X or 2X of IX3-CAS for the simple polarized light observation using IX3-AN, the contrast may be difficult to view in some cases.

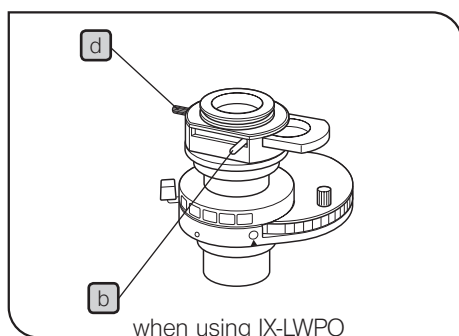
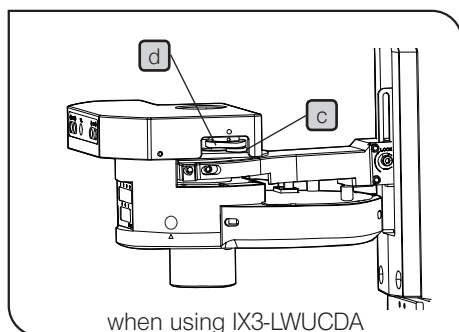
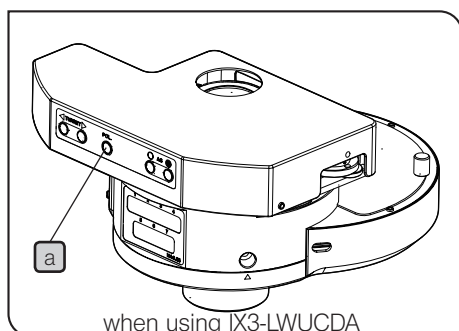

## 5-4 Reflected Light Fluorescence Observation (Separate Manual)

© Refer to the separate instruction manual (REFLECTED FLUORESCENCE SYSTEM).

## 5-5 Relief Contrast Observation (Separate Manual)

© Refer to the separate instruction manual (IX2-MLWCD or IX3-MLWCDA).

# 6 CAMERA RECORDING

## 1 Camera Adapter

The observed images can be acquired by attaching the camera adapter and the microscope digital camera to the left side port of IX73 or the trinocular tube (U-TR30H-2, U-TR30-2, etc.).

- ⊙ Be sure to adjust the parfocality before using a camera adapter. Otherwise, the focusing of the camera image will not match that of the image observed through eyepieces. When attaching the camera adapter, refer to the instructions of the camera adapter in use, too. For parfocality adjustment procedures, refer to the Instruction Manuals of the Camera Adapters.
- ⊙ When attaching the camera to the left side port, it is recommended to mount the support (column) between the camera and table top surface. If the camera is tilted, decentering may occur while replacing the objective lens.

## 2 Changing of Light Path

The light paths to the eyepiece and the left side port can be changed by using the light path selector lever on the side of the microscope (page 15).

	Eyepiece	/	Camera (Left side port)
👁	100%	/	0%
👁📷	50%	/	50%
📷	0%	/	100%

- ⊙ If acquiring the image by setting the light path as [Eyepiece 50%/ Left side port 50%], the light such as the fluorescent lamp may enter from the eyepiece to be reflected in the acquired image.
- ⊙ If the camera is attached to the camera port on the trinocular tube, refer to page 24.

## 3 Selecting the Camera Adapter Magnification

The image pickup area is determined by the size of the image sensor used in the TV camera or digital camera and the magnification of the camera adapter.

The following illustrations show the image pickup areas of camera adapters when using the WHN10X-H eyepieces (FN 22).

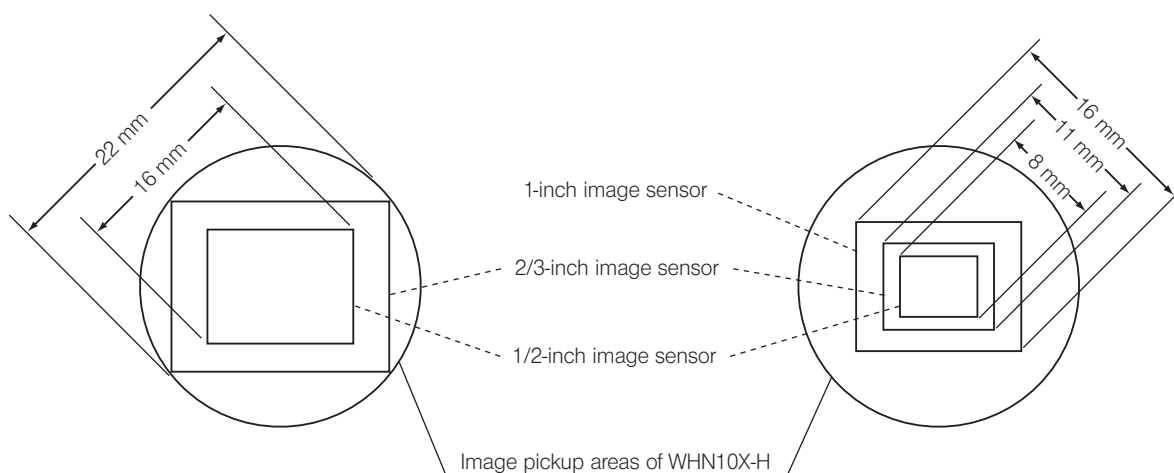

When a 0.5X camera adapter is used

When a 1X camera adapter is used

## 4 Installing the Camera Adapter

- ⊙ When attaching the camera adapter, refer to the instructions of the camera adapter in use, too.

When the U-TR30H-2 trinocular observation tube is used  
(in combination with the U-TR30H-2, U-TR30-2, U-TR30NIR)

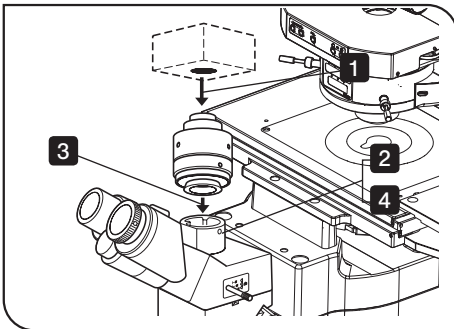

- 1 Screw the camera adapter securely into the C-mount camera.
- 2 Using the Allen screwdriver provided with the microscope, loosen the clamping screw on the camera adapter mount to remove the cap.
- 3 Insert the mount dovetail of the camera adapter into the camera adapter mount of the trinocular tube.
- 4 Tighten the clamping screw firmly.

When the left side port is used

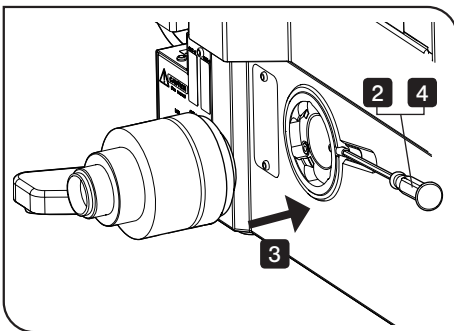

- 1 Screw the camera adapter securely into the C-mount camera.
- 2 Using the Allen screwdriver, loosen the left side port clamping screw of the microscope to remove the cap.
- 3 Insert the mount dovetail of the camera adapter into the camera adapter mount of the trinocular tube.
- 4 Tighten the clamping screw firmly.

- ⊙ When the left side port is not used, attach the cap.

- ⊙ If all conditions described below are met, flares may be noticeable in the left side port or in the camera port combining the intermediate tube IX-ATU + the trinocular tube U-TR30 series.
  - 1.6X or 2X of the coded intermediate magnification changer IX3-CAS is being used.
  - High contrast specimens are being observed.
  - Transmitted bright field observation is being used.
  - The aperture iris diaphragm is being narrowed down closer to the minimum.

In this case, the flares can be mitigated by slightly widening the aperture iris diaphragm.

- ⊙ If IX3-RFAL or IX3-RFALFE is attached so that the lamp house is placed on the left side facing to the microscope and also the operation area of U-DULHA is mounted facing up, the lamp house to be mounted to U-DULHA may hit and interfere with the camera attached to the left side port.
- ⊙ If U-DPCAD is attached to the left side port of the frame, the camera cannot be attached to the inside camera port depending on the camera size.
- ⊙ To acquire the 1X image by the left side port, combine U-TV1X-2 with U-CMAD3.
- ⊙ Attaching a heavy camera to the left side port may allow decentering the image due to the tilted adapter. It is recommended to reinforce the installation using a commercially available lab jack, etc.



# 7 TROUBLESHOOTING GUIDE

Under certain conditions, performance of the microscope may be adversely affected by factors other than defects. If problems occur, please review the following list and take remedial action as needed.

If you cannot solve the problem after checking the entire list, please contact your local Olympus representative for assistance.

Problem	Cause	Remedy	Page
a) The bulb does not light.	Power cord of the TH4 is unplugged.	Plug the power cord into a power outlet.	62
	Main switch of the TH4 is not " I " ON.	Set the main switch to " I " (ON).	14
	Bulb is burnt out.	Replace the bulb.	52
b) The bulb lights but the field of view is dark.	Lamp voltage is too low.	Increase the light intensity to an optimum voltage.	14
	Condenser is not well positioned.	Adjust the condenser height until the field iris diaphragm image is formed in the specimen plane.	28
	Light path selector knob is set for the left side port light path.	Change the light path.	15
	Too many filters are used.	Reduce the number of filters to the minimum required.	26
	Stage center plate is engaged in the light path.	Move the stage and place the specimen again.	18
	Field iris diaphragm is not opened wide enough.	Open the field iris diaphragm sufficiently.	27
c) Field of view is obscured or not evenly illuminated.	An objective that falls outside the condenser's illumination range is used.	Use a condenser that matches the objective.	28
	Field iris diaphragm is not properly centered.	Center the field iris diaphragm correctly.	28
	Field iris diaphragm is stopped down too far.	Open the field iris diaphragm sufficiently.	27
	A filter is stopped in an intermediate position.	Set the filter at the appropriate position.	26
d) Dirt or dust is visible in the field of view.	Dirt/dust on the specimen.	Clean thoroughly.	6
	Dirt/dust on the eyepieces.		
	Dirt/dust on a mirror unit.		
	Dirt/dust on the optical element.		
	Condenser is not correctly positioned and the frost filter Ø45 mm (45FR) or filter is focused.	Adjust the condenser height until the field iris diaphragm image is formed in the specimen plane.	28
e) Image glares.	Condenser is raised too high.	Lower to the proper position.	28
	Aperture iris diaphragm is stopped down too far.	Open the aperture iris diaphragm.	30

Problem	Cause	Remedy	Page
f) Visibility of observed image is poor. <ul style="list-style-type: none"> <li>Image is not sharp.</li> <li>Contrast is poor.</li> <li>Details are poorly visible.</li> </ul>	Objective in use is not designed for UIS2 series.	Replace with an objective designed for UIS2 optics.	-
	Correction collar on the objective equipped with correction collar is not adjusted.	Adjust the correction collar to acquire the best contrast.	32
	Front lens of the objective is dirty.	Clean the objective.	6
	The immersion oil appropriate with an oil immersion objective is not used.	Use Olympus immersion oil with the oil immersion objective, Olympus silicone oil with the silicone immersion objective and water with the water immersion objective.	31
	Immersion oil contains bubbles.	Remove bubbles.	-
	Inappropriate slide or cover glass thickness.	Replace with glass of appropriate thickness.	-
	Glass components (condenser, objective, eyepieces, culture vessels, etc.) are dirty.	Clean thoroughly.	6
	Ring slit and phase plate are not centered.	Center them correctly.	36
A plastic culture vessel is used.	Replace the plastic culture vessel with a glass vessel.	37	
g) A part or one side of the field of view is blurred.	Specimen is tilted with respect to the stage.	Place the specimen correctly on the stage and secure it with the stage clip.	18
h) Field of view of one eye does not match that of the other.	The interpupillary distance is incorrect.	Adjust the interpupillary distance.	23
	Incorrect diopter adjustment.	Adjust the diopter.	23
	You are not accustomed to parallel optical axis.	When looking into the eyepieces, do not stare at image from the beginning but see the overall field of view. It is sometimes recommended to turn your eyes away from the eyepieces, look far off and look into the eyepieces again.	-
i) After focused on the specimen, it will be defocused over time.	The thermal drift occurs due to the fluctuation of the room temperature.	Keep the room temperature constant as much as possible.	-
		When using IX3-SVR, the thermal drift could be small by loosening the holder fixing screws (4 pcs.) once and tightening them lightly,	55

# 8 SPECIFICATIONS

Item	Specification					
Optical system	UIS2 optical system					
Microscope Frame IX73P1F IX73P2F	Motorized light path selection 1 100% for observation light path 2 50% for observation light path, 50% for left side port 3 100% for left side port Focusing movable range Upper side: 6.5 mm or more from the original position Lower side: 3 mm or more from the original position Original position: 1 mm above the stage surface Left side port image magnification: 1X					
Illumination Column	Column for installing the lamp housing, with 30° tilting mechanism. Condenser holder up/down movement range: 88 mm Condenser refocusing mechanism is available. Designated bulb 12 V, 100 W long-life halogen bulb 12V100WHA-L (PHILIPS 7724) Power supply: Halogen lamp power supply unit TH4					
Observation Tube	Type	U-BI90	U-TBI90	U-TR30-2/U-TR30H-2	U-TR30NIR	
		Binocular	Tilting binocular	Trinocular	Trinocular	
	Field No.	22				
	Tube inclination	45°	35° to 85°	30°	30°	
	Interpupillary distance adjustment	50 to 76 mm				
	Diopter adjustment range	- 5 to + 5 diop				
	Intermediate tube	U-EPA2, GX-SPU, U-CA, etc.		IX-ATU		
	Light path selection	None		3 steps: ① BI 100% ② BI 20%, Camera 80% ③ Camera 100%	3 steps: ① BI 100% ② BI 50%, Camera 50% ③ Camera 100%	
Stage*	Type	IX3-SVR		IX3-SVL	IX2-SP	
	Size	240 mm (D) x 444.5 mm (W)		240 mm (D) x 437.5 mm (W)	240 mm (D) x 232 mm (W)	
	Movement mechanism	<ul style="list-style-type: none"> <li>· X- and Y-axis knob with adjustable tension.</li> <li>· Right long axis handle (can be mounted by reversing the right and left)</li> </ul>		<ul style="list-style-type: none"> <li>· X- and Y-axis knob with adjustable tension.</li> <li>· Left short axis handle (can be mounted by reversing the right and left)</li> </ul>	Not available	
	Movement range:	75 mm vertical (Y), 114 mm horizontal (X).		75 mm vertical (Y), 114 mm horizontal (X).	Movement range: (Combined with IX-MVR) 85 mm vertical (Y), 130 mm horizontal (X).	
Option	Replaceable center plate (Ø110 mm)		Replaceable center plate (Ø110 mm)	Replaceable center plate (Ø110 mm)		
Condenser*	Type	IX3-LWUCDA	IX2-LWUCD	IX2-MLWCD	IX-ULWCD	U-UCD8 (Used together with IX-ADUCD)
	NA	0.55	0.55	0.5	0.3	When a dry top lens is used :0.9 When an oil top lens is used :1.4
	WD	27 mm	27 mm	45 mm	73 mm	When a dry top lens is used :1.5 mm When an oil top lens is used :0.6 mm
	Turret	small hole 3, large hole 4	small hole 3, large hole 2	4	4	small hole 3, large hole 5
Operating environment	<ul style="list-style-type: none"> <li>• Indoor use.</li> <li>• Altitude: Max. 2000 meters</li> <li>• Ambient temperature: 5 to 40 °C (41 to 104 °F)</li> <li>• Maximum relative humidity: 80 % for temperatures up to 31 °C (88 °F) (without condensation) In case of over 31 °C (88 °F), the relative humidity is decreased linearly through 70 % at 34 °C (93 °F), 60 % at 37 °C (99 °F), and to 50 % at 40 °C (104 °F).</li> <li>• Supply voltage fluctuations: ±10%</li> <li>• Pollution degree: 2 (in accordance with IEC60664-1)</li> <li>• Installation/Overvoltage category: II (in accordance with IEC60664-1)</li> </ul>					
Transportation/ storage environment	<ul style="list-style-type: none"> <li>• Temperature: Min. -25°C, Max. 65°C</li> <li>• Humidity: Min. 0%, Max. 90% (without condensation)</li> </ul>					

\*For specifications of stages or condensers which are not described in this table, refer to the instruction manual provided separately.

# 9 ASSEMBLY



To ensure the performance, we recommend that you have your Olympus representative to assemble this microscope.

## 9-1 Assembly Diagram

The diagram below shows the sequence of assembly of the modules. The numbers indicate the order of assembly. The modules shown in the following diagram are merely the basic ones. For the modules which are not shown in the diagram, please consult your Olympus representative or the latest brochures.

**When assembling the microscope, make sure that all parts are free of dust and dirt, and avoid scratching any parts or touching glass surfaces. Also be sure to release the transport lock of the revolving nosepiece and light path selector by removing the screws before use (see pages 1 & 2).**

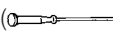
Assembly steps enclosed in  will be detailed on the subsequent pages.

⊙ All assembly operations are possible by using the 3 mm Allen screwdriver () and 4 mm Allen wrench () provided with the microscope. For assembly of the reflected fluorescence system and modules without descriptions, refer to the separate instruction manuals.

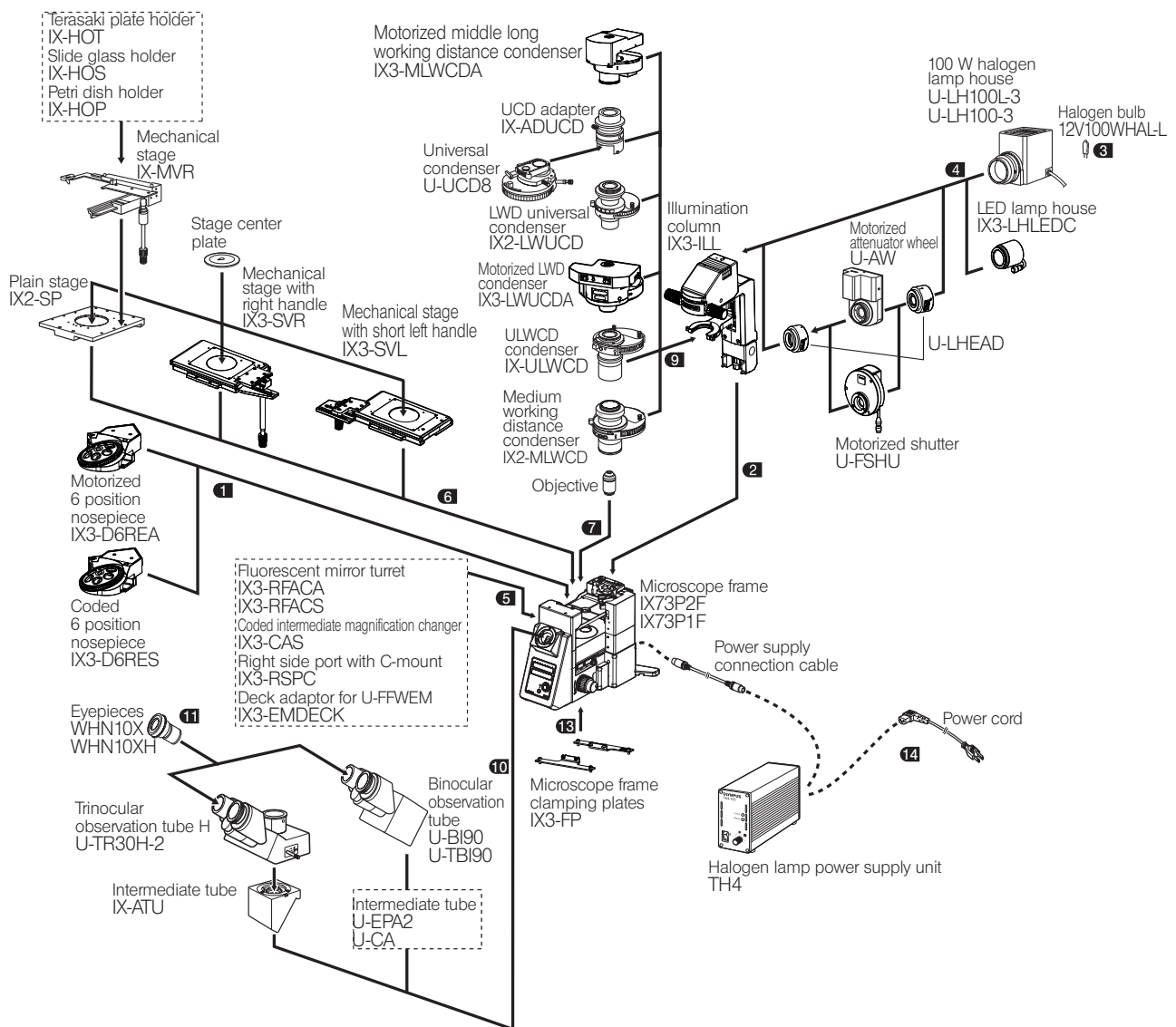

⊙ For the connection between cables and the control box, refer to the instruction manual of the control box to be used.

## 9-2 Detailed Assembly Procedures

### 1 Attaching the revolving nosepiece

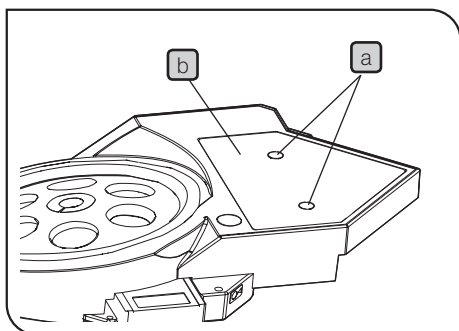

**CAUTION** To ensure the performance, we recommend that you have your Olympus representative to assemble the revolving nosepiece.

IX3-D6REA, IX3-D6RES

- 1 Loosen the cover fixing screw **a** (2 positions) by using the Phillips screwdriver, and remove the cover **b**.

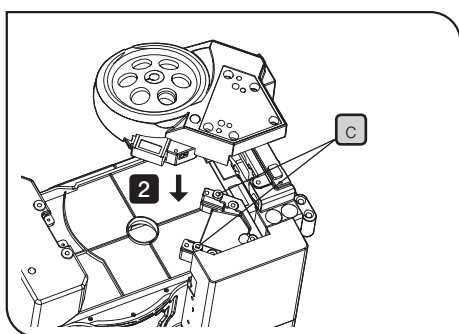

- 2 Insert the revolving nosepiece slowly into the positioning pins **c** (2 positions) in the upper area of the microscope.

**CAUTION** As the mounting holes of the positioning pins are small, insert the revolving nosepiece into the positioning pins carefully from the above paying attention not to tilt the revolving nosepiece.

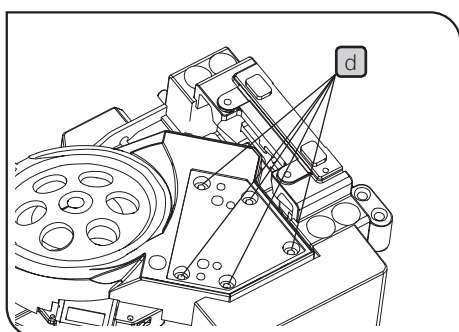

- 3 Tighten the revolving nosepiece fixing screws **d** (5 positions) by using the Allen wrench provided with the microscope.

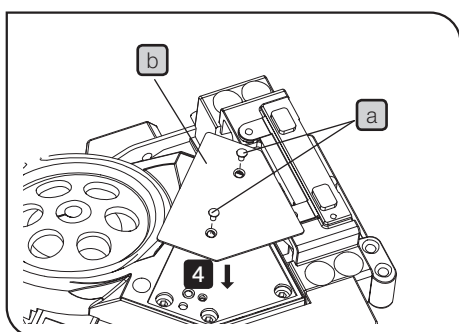

- 4 Place the cover **b** over the revolving nosepiece, and tighten the cover fixing screws **a** (2 positions) by using the Phillips screwdriver.

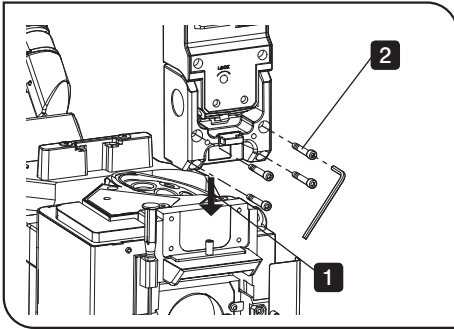

## 2 Mounting the Illumination Column

- 1 Aligning the two guide holes on the illumination column with the two protruding positioning pins on the microscope, gently fit the column onto the microscope from the above.
- 2 While holding the illumination column with one hand, insert the four provided Allen screws into the screw holes. Then tighten the screws with the provided Allen wrench.

**CAUTION** Do not tighten the screws with the illumination column inclined. Doing so may damage the screw sections.

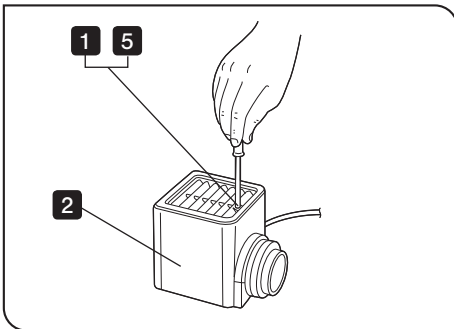

## 3 Attaching the Halogen Bulb

© The designated bulb model is the 12V100WHAL-L (PHILIPS 7724) halogen bulb.

- 1 Fully loosen the clamping screw at the top of the halogen lamp housing using the Allen screwdriver provided with the microscope.
- 2 Lift up the halogen lamp housing to remove it.
- 3 Tilt the bulb socket by 90° in the direction of the arrow.
- 4 While pushing down the bulb clamping lever (a), hold the halogen bulb (b) with gloves or a piece of gauze, insert the bulb pins (c) straight and fully into the pin position (d) on the lamp socket. Then return the lamp clamping lever gently back to the original position to clamp the bulb.

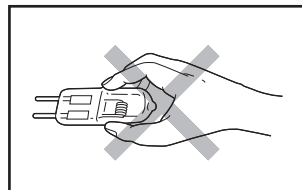
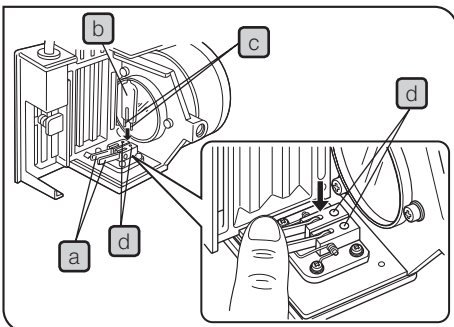
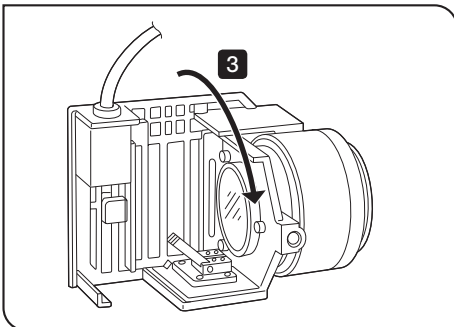

**CAUTION** To prevent reduced bulb life or cracking, do not touch the bulb with bare hands. If fingerprints are accidentally left on the bulb, wipe the bulb with a dry soft cloth.

- 5 Fit the halogen lamp housing from up and tighten the clamping screw by applying downward pressure.

### Caution for Bulb Replacement During or Right After Use

The bulb, lamp housing and areas near these will be extremely hot during and right after use.

Set the main switch to "O" (OFF), disconnect the power cord from the wall outlet, then allow the old bulb and lamp housing to cool before replacing the bulb with a new of the designated type.

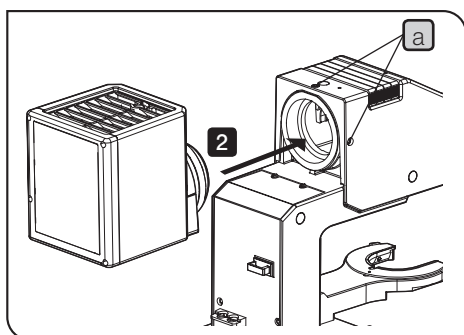

#### 4 Mounting the Lamp Housing

© This section describes the procedure using the halogen lamp housing (U-LH100L-3 or U-LH100-3) as an example, but the same procedure applies to the LED lamp house IX3-LHLEDC.

- 1 Loosen the two clamping screws **a** of the illumination column with the Allen screwdriver provided with the microscope.
- 2 Fit the lamp housing to the illumination column
- 3 Tighten the two clamping screws **a** of the illumination column.

## 5 Mounting to Microscope Deck

IX3-RFACA, IX3-RFACS, IX3-CAS, IX3-RSPC or IX3-EMDECK can be mounted to the microscope deck area. This section describes the procedure using IX3-RFACA as an example, but the same procedure applies to other units.

- ⊙ If the camera is attached to the left side port of the microscope, the unit may interfere with the camera while mounting the unit. In such a case, remove the camera before mounting the unit.
- ⊙ If you use the stopper screw for the analyzer slider IX3-AN, attach the stopper screw to the microscope first before attaching the fluorescence illuminator or the fluorescence mirror turret to the microscope decks. (page 43)

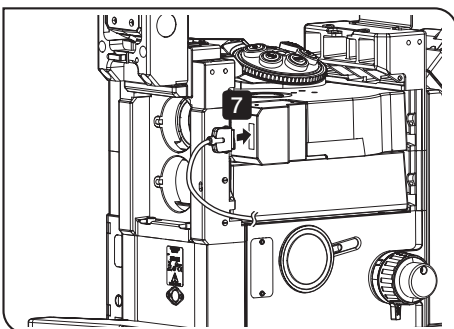
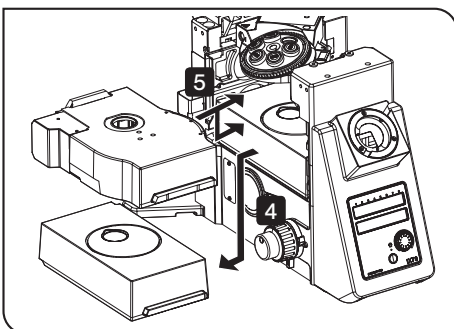
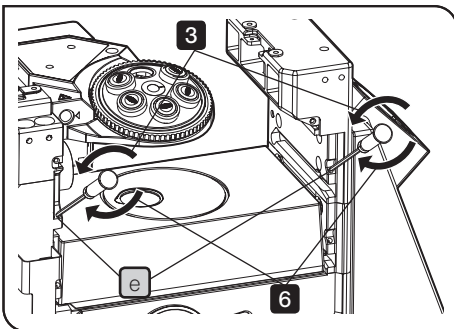
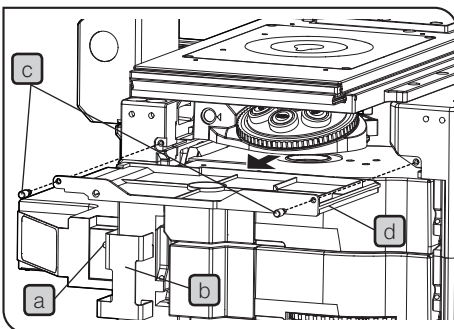

**1** When the cable cover is in use, remove the cable cover on the back side of the microscope. Turn the cable cover fixing knobs **a**, and remove the cover **b**.

**2** Remove the dust tray **d** placed on the left side of the microscope. Turn the fixing knobs **c** (2 pcs.) and remove the dust tray.

**3** By using the provided Allen screwdriver, loosen the fixing screws **e** (2 pcs.) of the deck where the fluorescence mirror turret is to be mounted until the fixing screws slightly come out from the screw holes.

**4** If the dummy box is attached to the deck, remove the dummy box.

**5** Insert the fluorescence mirror turret.

**6** Tighten the fixing screws **e** with the provided Allen screwdriver.

**7** After installation of the fluorescence illuminator, connect the interface cable U-FCBL100 to the mirror turret.

- ⊙ For the installation of the fluorescence illuminator, refer to the separate instruction manual entitled "Reflected Fluorescence System".

**8** Connect the opposite side of the interface cable U-FCBL100 to the IX3-CBM.

- ⊙ Do not dispose of the cover and dummy box and keep them in a safe place.

- ⊙ When you want to remove the fluorescent mirror unit, be sure to remove the reflected fluorescent illuminator first.

**9** Attach the dust tray **d** to the microscope and tighten the fixing knobs **c** (2 pcs.)

**10** When the cable cover is in use, attach the cable cover **b** to the back side of the microscope, and fix the one with the cable cover fixing knobs **a**.



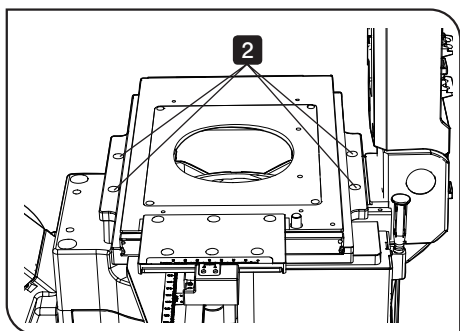

## 6 Attaching the Stage

- ⊙ When attaching the BX3-SSU, refer to the provided instructions.
- ⊙ The following stage mounting procedures are commonly applicable to the IX3-SVR, IX3-SVL, IX2-SP, IX2-GS and GX-SVR.
- ⊙ When mounting the mechanical stage IX-MVR, attach first the plain stage IX2-SP in advance (see the description on the bottom of this page).

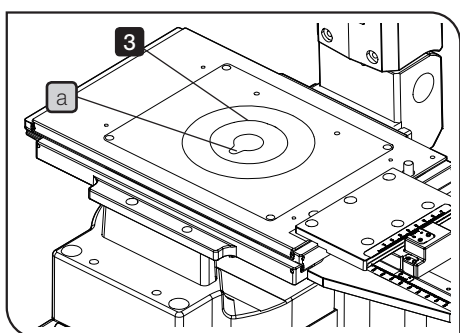

- 1 Gently place the stage on the microscope by aligning the stage mounting holes with the threaded holes on the frame.
  - 2 Insert the four provided Allen screws into the mounting holes . Tighten the screws using the provided Allen wrench.
- ⊙ Mount the stage so that the vertical (horizontal) direction of the stage is parallel to the vertical (horizontal) direction of the microscope.

- 3 Fit the stage center plate into the stage.

**CAUTION** The stage center plate is designed very thin so that the objective will not hit it when the revolving nosepiece is rotated. Do not subject the stage center plate to impact or excessive force, as this may deform it.

- ⊙ To facilitate confirmation of the objective front lens position and application of oil for oil immersion objectives, rotate the stage center plate so that the keyhole **a** will be facing the front.

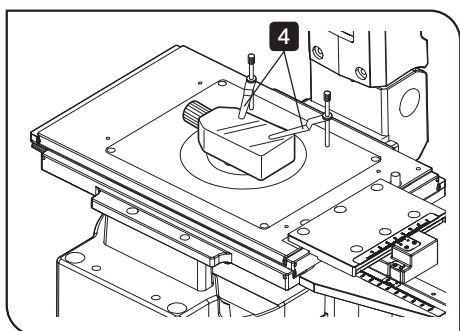

- 4 Screw the stage clips IX-SCL into the threaded holes provided on the stage top surface as needed.

- ⊙ By attaching IX3-SVR or IX3-SVL backward, it can be used as the long handle at left front or the short handle at right back. In this case, the movement range will be decreased and it will be difficult to check scales.

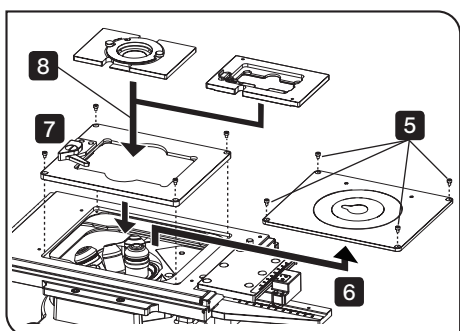

### Attaching the sample holder (IX3-SVR or IX3-SVL)

- 5 Remove the holder fixing screws (4 screws) by using the Allen wrench provided with the stage.
- 6 Remove the round stage center plate holder.
- 7 Set IX3-HOW-2 in the center of the stage, and attach the holder fixing screws.
- 8 If you are using IX3-HOW-2 or IX3-HO35D, set the sample holder in the center of IX3-HOW-2.

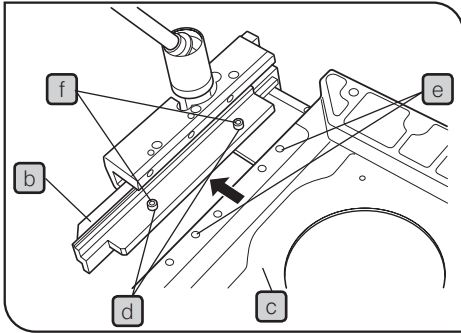

### Mechanical Stage (IX-MVR)

#### Attaching Procedure

- 1 Invert the mechanical stage **b** and the plain stage IX2-SP **c** upside down.
- 2 Align the two mounting holes **d** on the mechanical stage with the mounting holes **e** on the plain stage. Insert the two clamping screws **f** and tighten them using the Allen screwdriver.

#### CAUTION

The mechanical stage may also be attached to the left side of the plain stage. However, this will interfere with the operation of the stage travel knobs, focusing knobs and the revolving nosepiece.

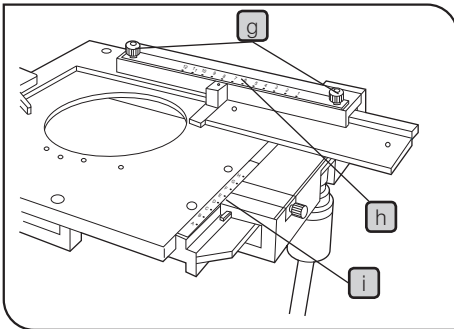

#### Attaching the scales

⊙ Scales for use with a 96-well microplate are provided with the mechanical stage.

- 1 Loosen the two clamping knobs **g** at the top of the stage's X-axis guide. Positioning the scale numerals correctly, place the X-axis scale **h** on the guide. Then tighten the clamping knobs.
- 2 For positioning the scale numerals correctly, place the Y-axis scale **i** on the top of the stage's Y-axis guide. The scale will be held in place magnetically.

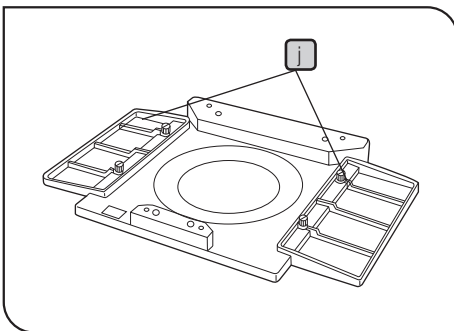

#### Attaching the substages CK2-SS

These plates can be attached in the same way as outlined in mechanical stage (IX-MVR) above.

⊙ When the mechanical stage is not used, stage extender plates **j** can be attached at both sides of the plain stage.

#### Attaching the positioning bracket

⊙ A flexible stalk for the coaxial X-axis and Y-axis knobs is employed with the mechanical stage IX-MVR. These stages are provided with a positioning bracket that allows the tilt of the stalk to be adjusted to suit the observer's preference.

- 1 Insert the stalk **l** of the flexible X-axis/Y-axis knobs into the U-shaped notch on the positioning bracket **k**.
- 2 Using the Allen screwdriver, tighten the clamping screw **m** of the bracket lightly to the stage.
- 3 Align the stage's center alignment index line with the edge of the upper stage.
- 4 Slide the positioning bracket to and fro in order to determine the most convenient stalk angle.
- 5 Tighten the bracket's clamping screw firmly.

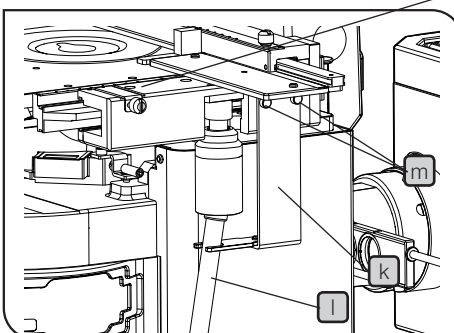

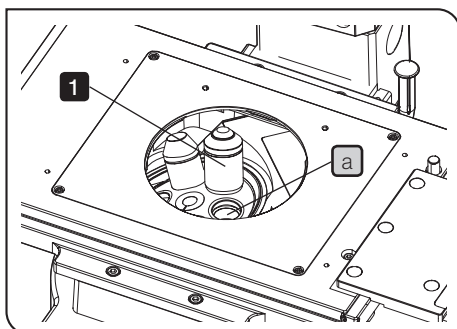

## 7 Attaching the Objectives

- 1 Remove the stage center plate and attach the objectives to the revolving nosepiece through the hole on the stage left by the plate.
  - ⊙ Attach the objectives in such a manner that the magnification increases from low to higher powers in a clockwise direction.
  - ⊙ Use the hand switch U-HSCBM to rotate the motorized 6 position nosepiece IX3-D6REA.

**CAUTION** Do not rotate the motorized revolving nosepiece manually. Otherwise, it will cause damage.

**CAUTION** In the inverted microscope, the front lens of the objectives faces upward, and is more exposed to contamination than the objectives of upright microscopes. Therefore, if there are empty positions **a** in the nosepiece, attach the dust caps provided.

- 2 After all objective lenses are mounted, fit the stage center plate into the stage.

## 8 Attaching the Condenser Refocusing Stopper

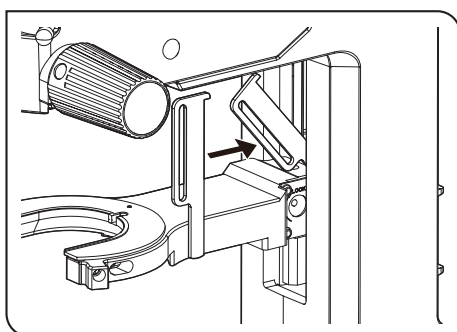

**CAUTION** If the condenser refocusing stopper is attached when the condenser attaching arm is placed at the lower position, the condenser may not be attached. Be sure to raise the condenser attaching arm before attaching the condenser refocusing stopper.

- ⊙ Mount the condenser refocusing stopper in the direction shown in the picture.

- 1 Insert the condenser refocusing stopper between the column and the condenser attaching arm.
- 2 Secure the condenser refocusing stopper with the fixing screw by using the Allen screwdriver provided with the microscope.

**CAUTION** Be careful not to drop the fixing screws.

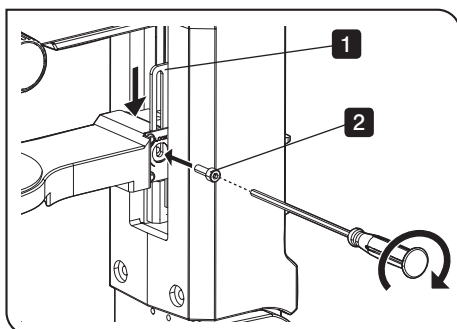

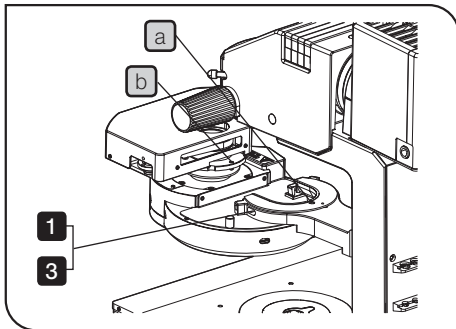

## 9 Attaching the Condenser

- 1 Loosen the condenser clamping screw.
- 2 Fit the condenser into the mount dovetail **a** on the condenser holder, and push in the condenser until its positioning pin **b** fits into the positioning groove on the mount dovetail.
- 3 Tighten the condenser clamping screw.

### Universal Condenser (U-UCD8)

#### Attaching onto the UCD Adapter

- 1 Using the Allen screwdriver, loosen the two setscrews **a** on the IX-ADUCD UCD adapter.
- 2 Push in the U-UCD8 universal condenser horizontally into the adapter until the condenser's positioning pin fits into the positioning groove on the mount dovetail.
- 3 Tighten the two setscrews **a** using the Allen screwdriver.

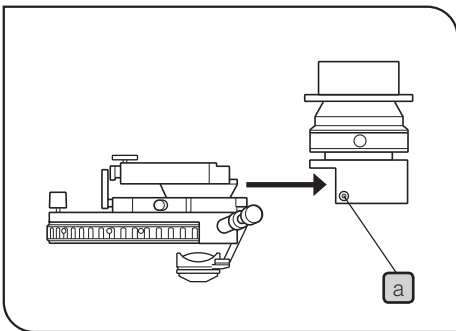

#### Attaching onto the Illumination Column

- 1 Rotate the condenser height adjustment knob **b** to raise the condenser to the upper limit position.
- 2 Loosen the condenser clamping knob **c**.
- 3 Insert the mount of the UCD adapter into the mount dovetail of the condenser holder (the condenser turret should be positioned on the right hand side). Push the UCD adapter horizontally into the condenser holder until the condenser's positioning pin fits into the positioning groove on the mount dovetail.
- 4 Tighten the condenser clamping knob **c**.

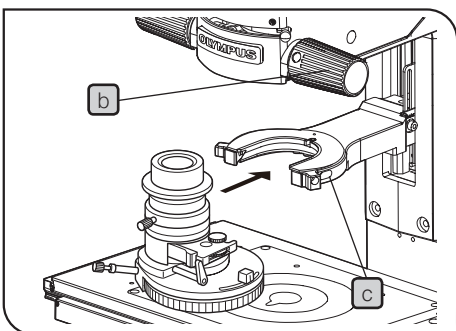

#### Optical element indices

The optical element indices attached on the U-UCD8 are not visible because the U-UCD8 is used upside down. Make your own reminder such as a list of the optical elements inserted in the turret. Use the provided number stickers/indication plates.

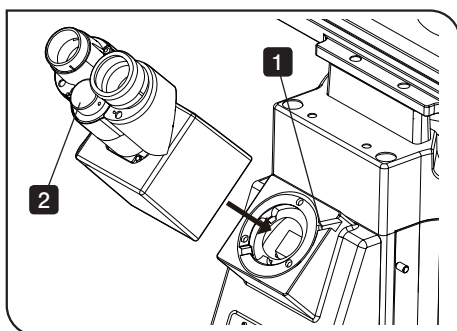

## 10 Attaching the Observation Tube

### Binocular Tube (U-BI90, U-TBI90)

- 1 Using the Allen screwdriver, loosen the observation tube clamping screw on the observation tube mount to remove the cap.
- 2 Attach the circular dovetail mount of the observation tube into the observation tube mount, placing the observation tube so that the interpupillary distance scale numbers are seen right side up. Then tighten the clamping screw to clamp the observation tube.

⊙ Normally, the distance from the surface of the desk to the eye point is approximately 430 mm. If it is desirable to lower the eye point position, the observation tube (provided it is other than the U-TBI90) may be detached, turned 180° and then attached on the observation tube mount again. This lowers the eye point height by approximately 30 mm.

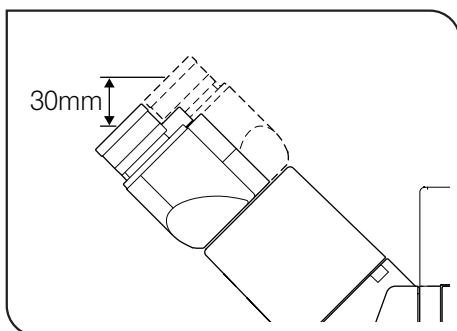

### Trinocular Tube (U-TR30-2, U-TR30NIR, U-TR30H-2)

⊙ First mount the IX-ATU intermediate tube.

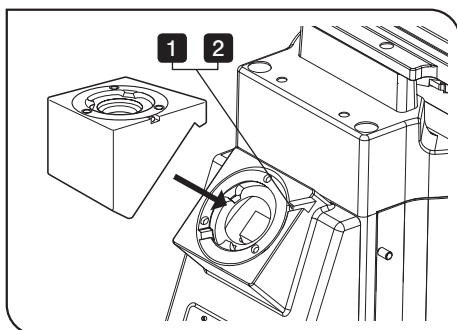

- 1 Using the Allen screwdriver, loosen the observation tube clamping screw on the observation tube mount to remove the cap.
- 2 Insert the circular dovetail mount of the intermediate tube into the observation mount so that its upper surface is flush with the microscope. Tighten the observation tube clamping screw to clamp the intermediate tube.

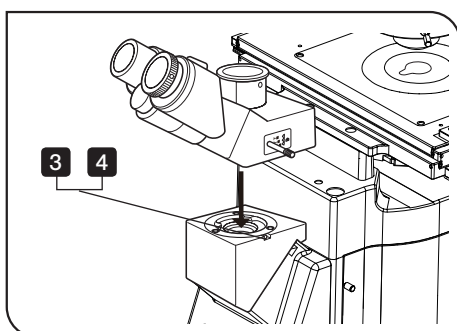

- 3 Using the Allen screwdriver, loosen the observation tube clamping screw on the intermediate tube's observation tube mount.
- 4 Insert the circular dovetail mount of the observation tube into the intermediate tube's observation tube mount so that the binocular eyepiece sleeves face toward the front. Then tighten the observation tube clamping screw firmly.

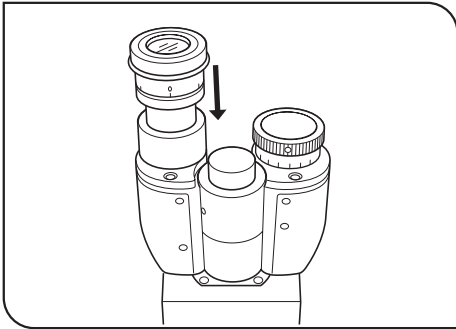

## 11 Attaching the Eyepieces

- 1 Remove the eyepieces' dust caps.
- 2 Insert the WHN10X-H eyepiece with helicoid into the eyepiece sleeve without helicoid (shown on the left in the figure).
- 3 Insert the WHN10X eyepiece without helicoid into the eyepiece sleeve with helicoid (shown on the right in the figure).

## 12 Using the Accessory Mounting Holes

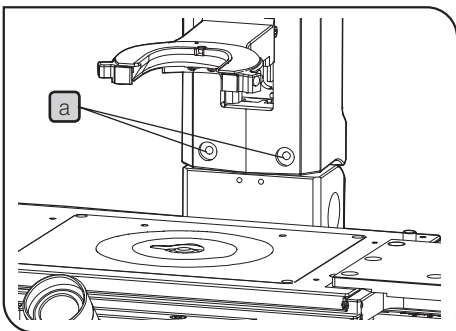

- ⊙ Twelve threaded holes **a** are provided on the microscope for mounting accessories such as a micromanipulator.
- ⊙ Insert the cylindrical material (diameter: less than 11.5 mm; height: higher than 5 mm) between the microscope, and mount accessories.

**CAUTION** The applicable screws are M6 screws. The screws can be inserted into the microscope up to a depth of 10 mm. Select the screw length in accordance with this.

### 13 Using the Frame Fix Plate (IX3-FP)

**CAUTION** The microscope should be inclined to attach the frame fix plates. Therefore, it is required to remove the specimen and dish that are not clamped onto the frame before proceeding.

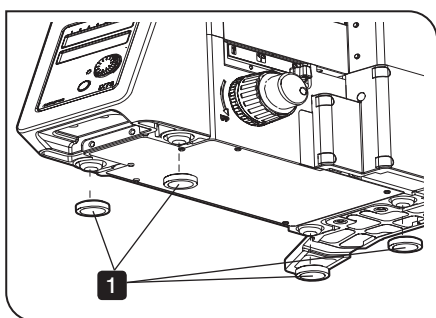

#### Attaching the Base Mount Ring

- 1 Attach the base mount ring to the rubber leveling pad at the bottom of the microscope.

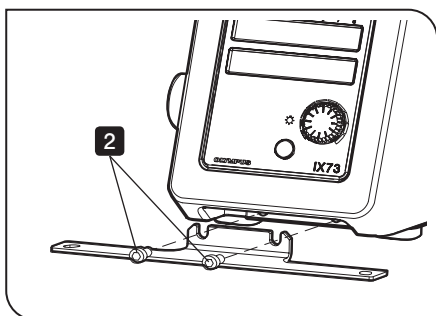

#### Attaching the Fixing Plate

- 2 Attach the fixing plate on the front side of the microscope and fix it by using a commercially available 5 mm Allen wrench.

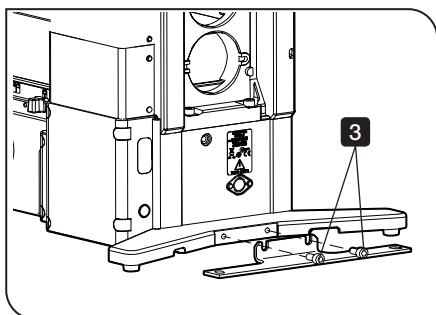

- 3 Attach the fixing plate on the back side of the microscope and fix it by using the commercially available 5 mm Allen wrench.

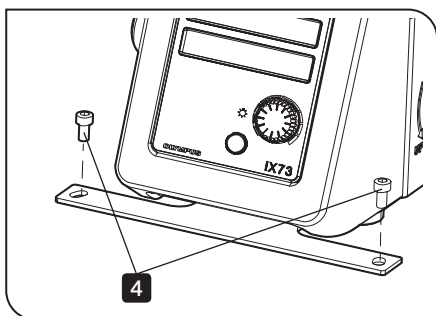

- 4 Tighten the fixing screw by using the commercially available 5 mm Allen wrench to secure the microscope on the anti-vibration table.

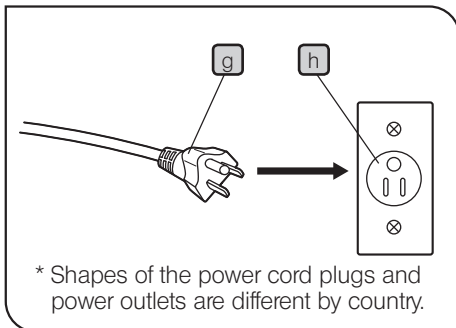
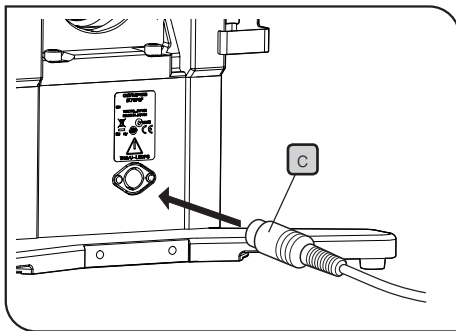
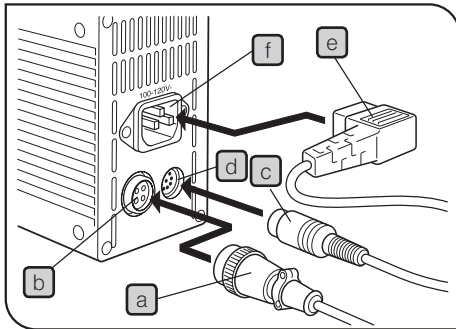

## 14 Connecting the Cables

### CAUTION

- Cables and cords are vulnerable when bent or twisted. Never subject them to excessive force.
- Make sure that the main switch of the power supply is set to “OFF” before connecting cables.

Connecting to TH4 or U-LEDPS

- 1 Connect the plug **a** of the lamp housing or illumination column to the connector **b** firmly.
- 2 Connect the hand switch plug or power supply connection cable **c** to the connector **d**.
- 3 Connect the other end of the power supply connection cable **c** to the right side of the IX73 frame.
- 4 Connect the power cord connector **e** to the connector **f** firmly.
- 5 Connect the power cord plug **g** to a wall outlet **h**.

### Motorized modules

© Refer to the separate instruction manual (IX3-CBM).

### Coded function modules

© Refer to the separate instruction manual (U-CB5S).



## 15 Cable Distributions

- ◎ The cables can be laid properly by using the cable holders provided with each module.
  - IX3-CBM (4 pcs.)
  - Back side of IX3-ILL (2 pcs. they have already been attached.)
  - On IX3-LWUCDA (1 pc. it has already been attached.)
- ◎ Attach the cable holders provided with IX3-CBM to the microscope (IX73P1F or IX73P2F) as needed.
- ◎ The number of the cable holders used vary depending on the modules used in the system.
- ◎ The basic positions for attaching the cable holders and the method of cable distribution are illustrated below.
- ◎ If the cable holders are attached in widely deviated positions, the cable may become unable to reach the connector. Be sure to attach the cable holders while confirming that their positions allow the cable to reach the connector.

**CAUTION** Bundle the cables loosely giving plenty of length so that they won't be stretched when operable parts move. Particularly, do not bundle the cables connected to the stage or the condenser with tension in all movement ranges.

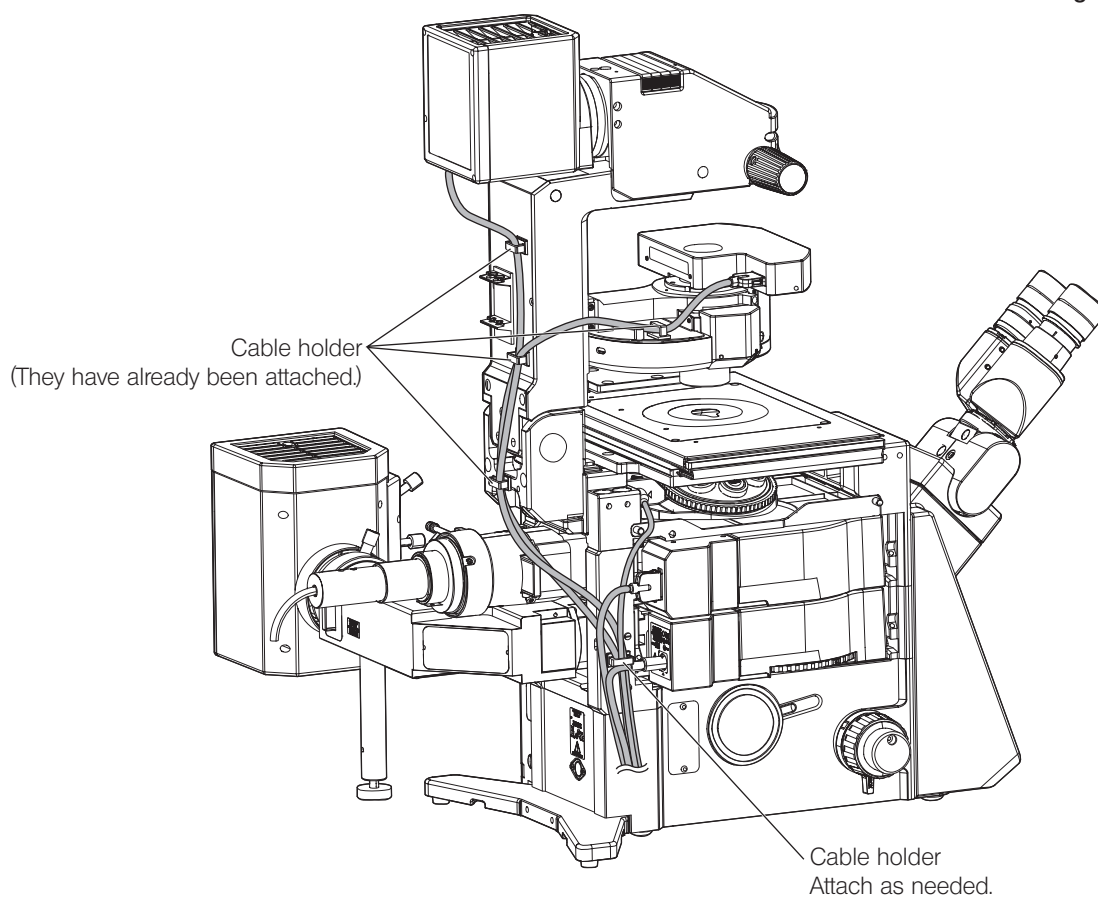

## 16 Cable Cover

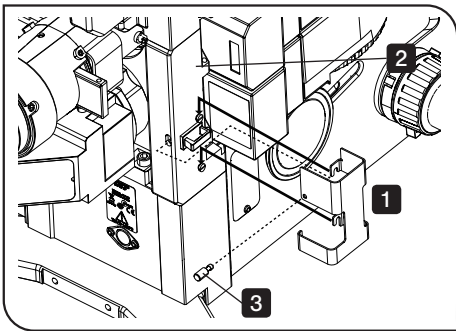

◎ The cable cover is provided with IX3-CBM.

◎ Attaching the cable cover to the microscope will allow you to bundle the cables coming from the microscope.

- 1 Hook the cable cover so that the stopper of the microscope is aligned with the notch of the cable cover.
- 2 Put the cables coming from the microscope through the cable cover.
- 3 Tighten the fixing knob to the microscope.

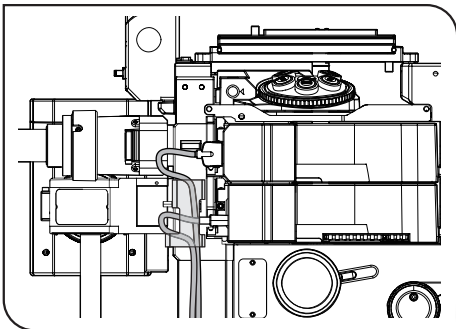

◎ Put the cables coming from the modules attached to 1st Deck and 2nd Deck through the cable cover as shown in the picture on the left.

The cables coming from other modules are put through the cable cover from top to down.

# 10 LAMP HOUSING INSPECTION SHEET

- Study the instruction manual for the lamp housing before inspection.
- For safe use of the lamp housing, we recommend performing the following inspection periodically (every time you replace the lamp and at least every 6 months).
- The table below identifies the check items to be observed. Put (X) if not applicable or (✓) if applicable.
- If there is any (✓) mark noted, immediately stop use of the product, and contact Olympus for detailed inspections or replace the lamp housing.
- If you detect an abnormality other than that listed below or with other Olympus product, also stop the use of the product and contact Olympus for detailed inspections.
- Note that service, replacement and detailed inspections are charged after expiration of the warranty period.

If you have any questions, please contact Olympus.

Check items	Check results (Date)			
	/	/	/	/
1. More than 8 years have passed since original purchase or the total power ON time has exceeded 20,000 hours.				
2. Illumination flickers when you move the lamp cable or lamp housing.				
3. Lamp cable is unusually hot to the touch.				
4. Scorching or burning odor is produced during use.				
5. Deformation, backlash, or looseness, etc. when you assemble the lamp housing. (Impossibility of removing the top section of lamp housing when you attempt to replace the lamp, etc.)				
6. Discoloration, deformation or cracking of the lamp housing.				
7. Melting, crack, deformation or solidification of the lamp cable or a wiring part.				
8. Increased frequency of servicing compared to similar devices put into use at the same time as the lamp housing.				

\* When the Check Result columns become insufficient, copy this sheet.

## ■ PROPER SELECTION OF THE POWER SUPPLY CORD

If no power supply cord is provided, please select the proper power supply cord for the equipment by referring to “ Specifications ” and “ Certified Cord ” below:



















**CAUTION:** In case you use a non-approved power supply cord for Olympus products, Olympus can no longer warrant the electrical safety of the equipment.

### Specifications

Voltage Rating	125V AC (for 100-120V AC area) or, 250V AC (for 220-240V AC area)
Current Rating	6A minimum
Temperature Rating	60°C minimum
Length	3.05 m maximum
Fittings Configuration	Grounding type attachment plug cap. Opposite terminates in molded-on IEC configuration appliance coupling.

**Table 1 Certified Cord**

A power supply cord should be certified by one of the agencies listed in Table 1 , or comprised of cordage marked with an agency marking per Table 1 or marked per Table 2. The fittings are to be marked with at least one of the agencies listed in Table 1. In case you are unable to buy locally in your country the power supply cord which is approved by one of the agencies mentioned in Table 1, please use replacements approved by any other equivalent and authorized agencies in your country.

Country	Agency	Certification Mark	Country	Agency	Certification Mark
Argentina	IRAM		Italy	IMQ	
Australia	SAA		Japan	JET, JQA,	
Austria	ÖVE		Netherlands	KEMA	
Belgium	CEBEC		Norway	NEMKO	
Canada	CSA		Spain	AEE	
Denmark	DEMKO		Sweden	SEMKO	
Finland	FEI		Switzerland	SEV	
France	UTE		United Kingdom	ASTA BSI	
Germany	VDE		U.S.A.	UL	
Ireland	NSAI				

**Table 2 HAR Flexible Cord**

APPROVAL ORGANIZATIONS AND CORDAGE HARMONIZATION MARKING METHODS

Approval Organization	Printed or Embossed Harmonization Marking (May be located on jacket or insulation of internal wiring)		Alternative Marking Utilizing Black-Red-Yellow Thread (Length of color section in mm)		
			Black	Red	Yellow
Comite Electrotechnique Belge (CEBEC)	CEBEC	⟨HAR⟩	10	30	10
Verband Deutscher Elektrotechniker (VDE) e.V. Prüfstelle	⟨VDE⟩	⟨HAR⟩	30	10	10
Union Technique de l'Electricite' (UTE)	USE	⟨HAR⟩	30	10	30
Instituto Italiano del Marchio di Qualita' (IMQ)	IEMMEQU	⟨HAR⟩	10	30	50
British Approvals Service for Electric Cables (BASEC)	BASEC	⟨HAR⟩	10	10	30
N.V. KEMA	KEMA-KEUR	⟨HAR⟩	10	30	30
SEMKO AB Svenska Elektriska Materielkontrollanstalter	SEMKO	⟨HAR⟩	10	10	50
Österreichischer Verband für Elektrotechnik (ÖVE)	⟨ÖVE⟩	⟨HAR⟩	30	10	50
Danmarks Elektriske Materialkontroll (DEMKO)	⟨DEMKO⟩	⟨HAR⟩	30	10	30
National Standards Authority of Ireland (NSAI)	⟨NSAI⟩	⟨HAR⟩	30	30	50
Norges Elektriske Materielkontroll (NEMKO)	NEMKO	⟨HAR⟩	10	10	70
Asociacion Electrotecnica Y Electronica Espanola (AEE)	⟨UNED⟩	⟨HAR⟩	30	10	70
Hellenic Organization for Standardization (ELOT)	ELOT	⟨HAR⟩	30	30	70
Instituto Portages da Qualidade (IPQ)	np	⟨HAR⟩	10	10	90
Schweizerischer Elektro Technischer Verein (SEV)	SEV	⟨HAR⟩	10	30	90
Elektriska Inspektoratet	SETI	⟨HAR⟩	10	30	90

Underwriters Laboratories Inc. (UL)  
Canadian Standards Association (CSA)

SV, SVT, SJ or SJT, 3 X 18AWG  
SV, SVT, SJ or SJT, 3 X 18AWG





# **OLYMPUS<sup>®</sup>**

---

Manufactured by



**OLYMPUS CORPORATION**

Shinjuku Monolith, 3-1, Nishi Shinjuku 2-chome, Shinjuku-ku, Tokyo, Japan

Distributed by

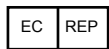

**OLYMPUS EUROPA HOLDING GMBH**

Wendenstrasse 14-18, 20097 Hamburg, Germany

**OLYMPUS AMERICA INC.**

3500 Corporate Parkway, Center Valley, Pennsylvania 18034-0610, U.S.A.

**OLYMPUS SINGAPORE PTE LTD.**

491B River Valley Road, #12-01/04 Valley Point Office Tower, Singapore 248373

**OLYMPUS AUSTRALIA PTY. LTD.**

31 Gilby Road, Mount Waverley, VIC., 3149, Melbourne, Australia

**OLYMPUS LATIN AMERICA, INC.**

5301 Blue Lagoon Drive, Suite 290 Miami, FL 33126, U.S.A.

